

INSTALLATION INSTRUCTIONS



DJ RVS III RADAR MOUNTING BRACKET KITS

Several mounting options are available with the Dj RVS III Radar. DICKEY-john has 2 bracket kits available for purchase which will meet most application requirements.

- A standard pipe mounting plate (P/N 467830760) for use when the implement already has a 3/4" diameter pipe mount in a suitable location, and
- A mounting pipe kit (P/N 456402100) to be used in combination with the standard pipe mounting plate.

DJ RVS III RADAR SENSOR KIT P/N 467831000S1

1. Dj RVS III Radar Sensor
2. Installation Instruction
3. Vibration Isolation Mounting hardware (P/N 467830781)
 - Isolation Mounts (3)
 - 1/4" x 20 Nuts (6)
 - 1/4" ISP Lockwashers (6)
 - 1/4" Split Ring Lockwashers (6)

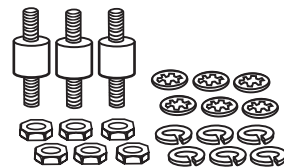
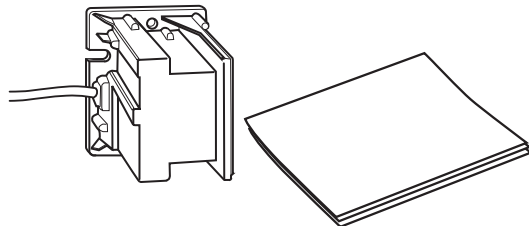

INSTALLATION INSTRUCTIONS



DJ RVS III MOUNTING BRACKET KIT P/N 467830760

1. Mounting Bracket
2. U-Bolts 1 1/8" x 2" x 1/4 - 20 (2)
3. 1/4" Split Ring Lock Washers (4)
4. 1/4 - 20 Nuts (4)

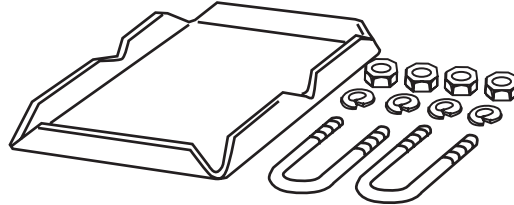

DJ RVS III "L" PIPE MOUNTING BRACKET KIT P/N 456402100

1. "L" Pipe Mounting Bracket
2. 3/8 - 16 x 1 1/2" Bolts (2)
3. 3/8 Split Ring Lock Washers (2)
4. 3/8 Nuts (2)

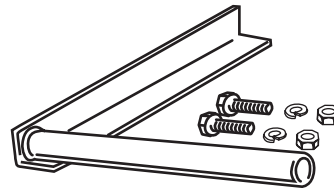

24V DJ RVS III ADAPTER CABLE ASSEMBLY P/N 467830812

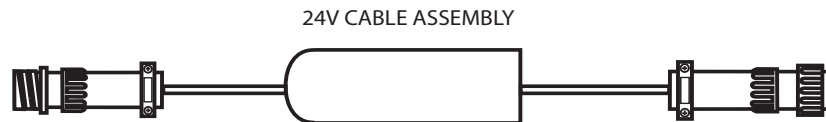

INSTALLATION INSTRUCTIONS



MOUNTING

SELECTING MOUNTING LOCATION

1. Park the vehicle on level ground. This is necessary in order to install the radar at the proper angle with respect to the ground. Refer to Figure 1 for illustration.

Figure 1

Proper Radar Placement

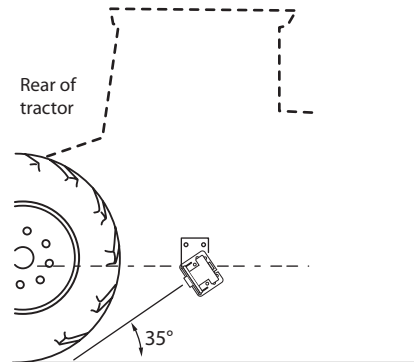

NOTE: There may be instances where the radar will have to be oriented facing forward, but rear facing is preferred to offer more physical protection to the radar sensor.

NOTE: Care must be exercised when selecting mounting location. The sensor must have an unobstructed cone-shaped view of the ground. If a vehicle tire, hose, or liquid line is within the cone-shaped area, erroneous readings may result.

2. The following list describes some of the precautions that should be followed when selecting a mounting location.
 - a. The face of the radar must have an unobstructed view of the ground. The area that must remain unobstructed is cone-shaped from the face of the radar to the ground, as illustrated in Figure 2. The pattern of the radar signal on the ground is oval-shaped due to the installation angle. The size of the oval pattern is dependent on the radar height above ground.

Figure 2

Unobstructed Mounting Location

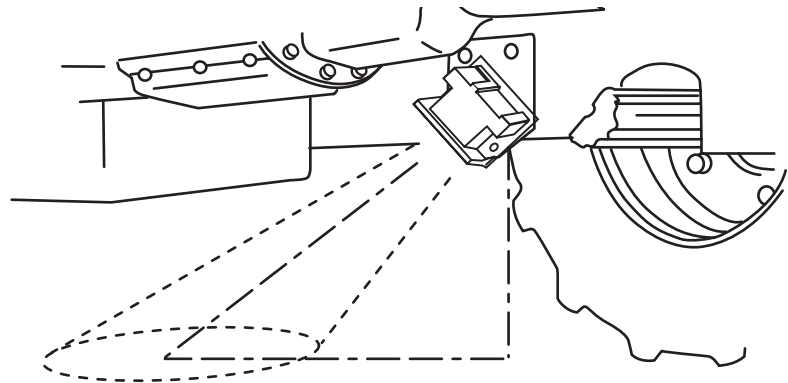

INSTALLATION INSTRUCTIONS



Following is the pattern size for the indicated height.

RADAR HEIGHT	PATTERN SIZE (OVAL)
18 inches	18.8 x 12.7 inches
24 inches	24.17 x 17.2 inches
48 inches	31.0 x 25.6 inches

NOTE: The most critical dimensions are the placement of the three Radar III Sensor mounting holes. However, these holes may be ovaled out if they are not drilled in the exact location.

- b. Fluids do not drip on radar face area.
- c. The radar is away from all heat sources.
- d. The radar face housing does not touch the vehicle.
- e. The radar is protected from stubble and debris.
- f. It is recommended that the radar be installed facing the rear of the vehicle.
- g. The radar mounting location must have a minimal amount of vibration; excessive vibration may cause erroneous MPH readings with the vehicle stationary.

Figure 3

Radar Placement

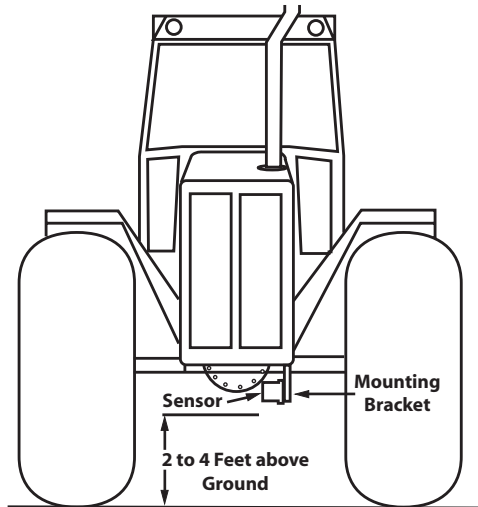

INSTALLATION INSTRUCTIONS



PIPE MOUNTING BRACKET KIT

The Pipe Mounting Bracket Kit consists of a mounting plate and two U-bolts with lock washers and nuts. This kit is used to install the Radar on the “L” pipe mounting bracket per Figure 4. If the pipe mounting bracket is already installed, proceed to STEP 3; otherwise continue as follows.

Figure 4

Typical Pipe Mounting Locations

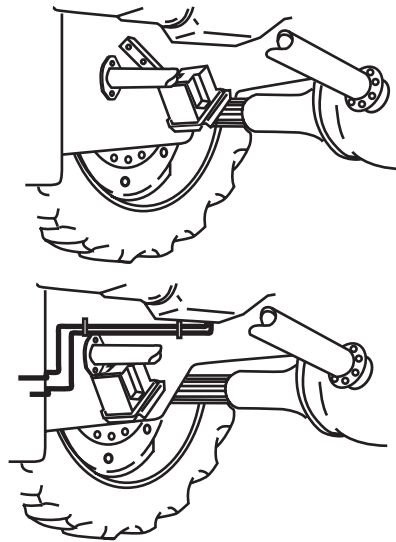

1. Select a location (on the inside of the main frame, when possible) to install the radar “L” pipe mounting bracket. If possible, select a location where two existing bolts can be used and drill matching holes in the angle iron on the pipe mounting bracket. The preceding illustration shows some typical mounting positions.
2. If two existing bolts are not at the selected location, drill two holes in the mounting surface and two matching holes in the angle iron on the pipe mounting bracket (check the opposite side of the drilling surface for wires, hoses, etc.). Before installing the pipe mounting bracket, make certain the radar can be positioned over the pipe extending from the bracket. If not, the radar will have to be installed on the pipe before the mounting bracket is secured to the mounting surface.

IMPORTANT: Welding the bracket to the mounting surface is NOT RECOMMENDED. Excessive frame vibration may necessitate the relocation of the mounting bracket to a more stable location. Also, do not weld the bracket in a location that inhibits the removal of the radar.

INSTALLATION INSTRUCTIONS



CAUTION

If at any time an arc welder is used on the vehicle, or anything connected to the vehicle, disconnect all power and ground leads that provide power for the system. Failure to do so can result in damaged electronic components, in which case the warranty will be VOID.

3. Refer to the following illustration and install the radar mounting hardware as shown. Make sure the radar is above the pipe with its face toward the rear of the vehicle (if possible) and the enclosure seam placed down toward the mounting plate. Tighten the three nuts holding the isolation mounts to the sensor. Tighten the radar to the Mounting Plate using three nuts and lock washers. Tighten the U-bolts until the radar will hold position but can still be adjusted as needed on the pipe.

Figure 5
Radar Mounting

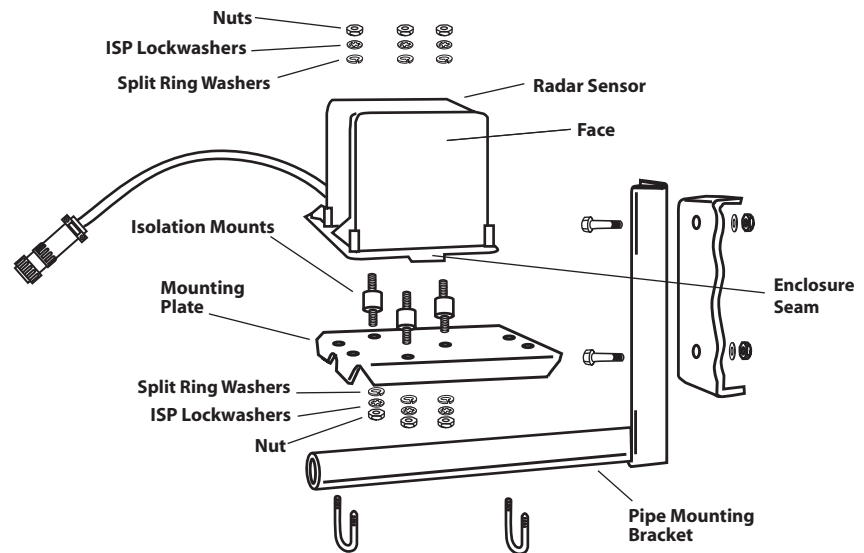

CAUTION

Do not exceed 30 - 35 lbs per inch (3.0 - 3.5 N.M.) of torque when tightening the three Isolation mounts and three 1/4" x 20 bolts securing the Radar III to the mounting bracket. Over tightening may fracture the Radar sensor housing.

INSTALLATION INSTRUCTIONS



4. Refer to Figure 6 and hold the mounting bracket template for pipe installation behind the the radar sensor, over the pipe as shown. (template is located on page 12 of this instruction)

Figure 6

Pipe Mounting Installation

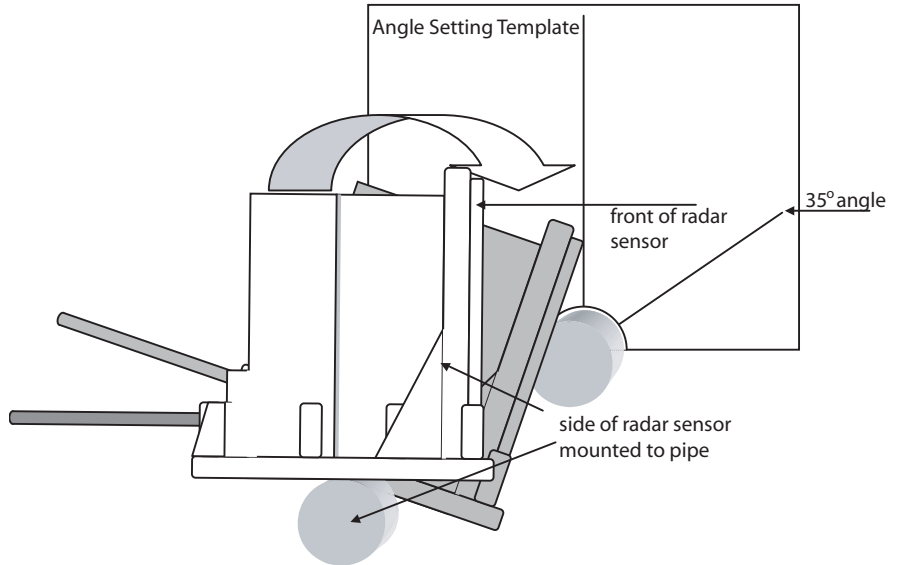

5. Rotate the radar on the mounting pipe until the front of the radar lines up with the 35° angle on the template. Tighten the mounting hardware.

IMPORTANT: The vehicle must be on level ground when the angle is set.

IMPORTANT: Make certain that the housing of the radar does not come in contact with the vehicle frame or the mounting bracket. Such contact can cause erratic readings by introducing electrical noise into the radar. Under the proper circumstances, such contact may cause electrical damage to the radar.

INSTALLATION INSTRUCTIONS



POWER CONNECTION

Refer to the following diagrams (Figure 7 and 8) illustrating the connection relationship for both 12V and 24V systems.

1. The Radar is a 12V system that can be connected to an implement operating on 12V by routing the radar harness to the console and attaching the mating connectors.

Figure 7

12V Power Connection

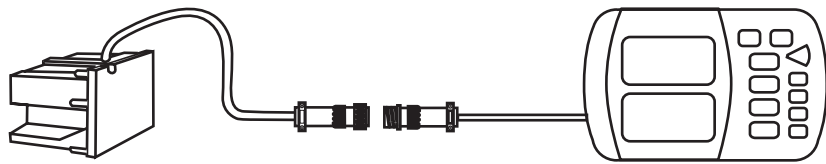

1. A 24V adapter assembly is available for implements operating with 24V systems. The adapter assembly is attached between the console and radar and connected to the corresponding mating connectors.

Figure 8

24V Power Connection

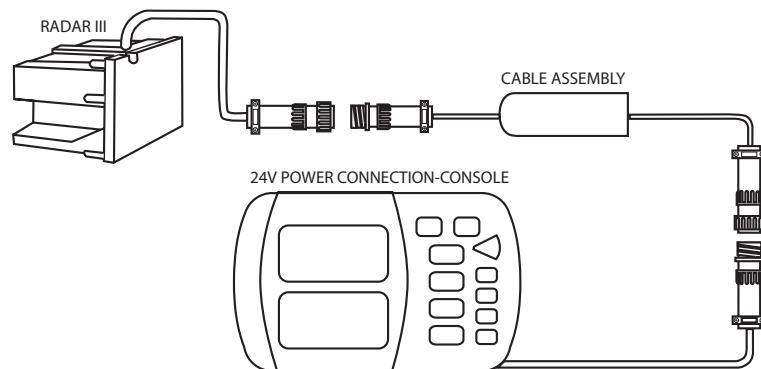

CAUTION

All 24V vehicles must use the Adapter Cable Assembly provided with the kit. Failure to do so may cause electrical damage to the radar.

INSTALLATION INSTRUCTIONS



IMPORTANT: Do not secure the cable until the radar has been checked for vibration. Excessive vibration may cause ground speed (MPH) readings to be above zero when the vehicle is stationary.

VIBRATION CHECK

To check for vibration, start the vehicle engine and slowly increase engine RPM (while watching the ground speed readout) to approximately 1800. If the ground speed readings are above zero, the radar must be mounted in an alternate, more stable location. After the radar readings have been checked and found to be stable, secure the radar cable where it will not be damaged.

CONSOLE CALIBRATION

When the radar is installed and the system is operational, the radar or console must be calibrated.

Refer to the Installation and Operation Manual of your monitor console and perform the ground speed (distance) calibration procedure as described.

INSTALLATION INSTRUCTIONS



PLATE MOUNTING BRACKET

(Fabricated By User)

For applications that cannot use the provided Dickey-john mounting brackets, Figure 9 provides a dimensional drawing of a plate mounting bracket that can be fabricated by the installer. The mounting plate must be made of 5/16 inch or thicker steel plate.

IMPORTANT: Using steel plate less than 5/16 inch may allow the radar velocity sensor to vibrate which could cause erroneous MPH (kph) readings.

Figure 9

Plate Mounting Bracket Dimensions for Fabricated Mounting Bracket

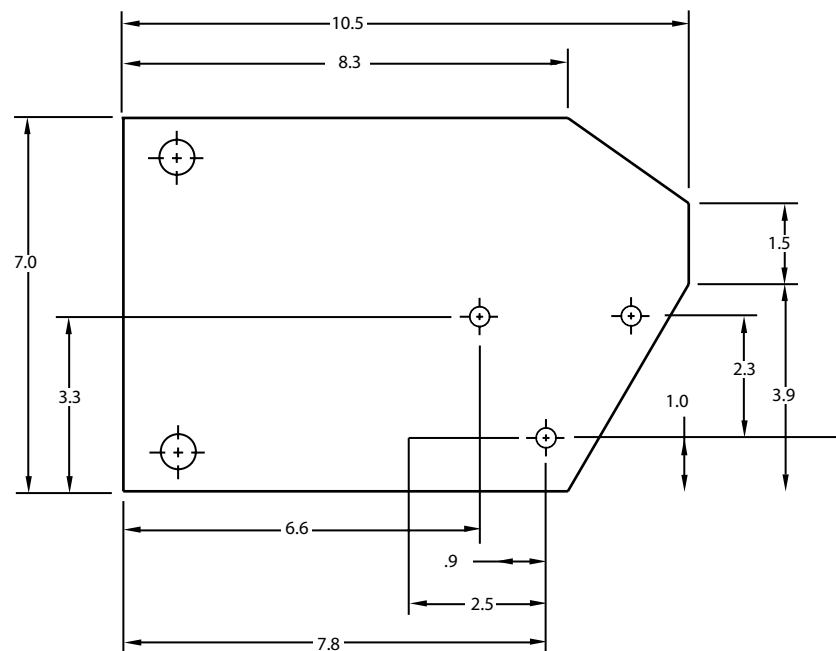

Suggested mounting hardware for a 5/16 inch plate is as follows:

1. 3/8 - 16 x 1 1/2" Bolts (2)
2. 3/8 Split Ring Lockwashers (2)
3. 3/8 Nuts (2)
4. Vibration Isolation Mounting hardware (P/N 467830781)
 - 1/4" x 20 Nuts (6)
 - Isolation Mounts (3)
 - 1/4" ISP Lockwashers (6)
 - Split Ring Washers (6)

IMPORTANT: Make certain the mounting plate does not extend past the radar housing. Metal beside the face area can cause improper operation of the Radar.

INSTALLATION INSTRUCTIONS



INSTALLATION OF FABRICATED MOUNTING PLATE

NOTE: Care must be taken when tightening the isolation mounts. Over-tightening the mounts may cause the rubber to tear and the mount to break.

Refer to Figure 10 diagram to install the Radar on the flat plate mounting bracket, with the enclosure seam on the side. Make certain spacers are installed as shown.

Figure 10

Fabricated Mounting Plate Installation

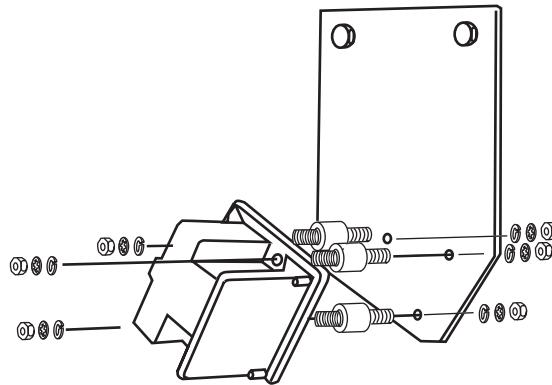

CAUTION

Do not exceed 30 - 35 lbs per inch (3.0 - 3.5 N.M.) of torque when tightening the three Isolation mounts and three 1/4" x 20 nuts securing the Radar to the mounting bracket. Over tightening may fracture the Radar housing.

NOTE: If required, the "B" mounting hole can be oveled out to provide the rotation necessary to adjust the radar angle.

Refer to the following illustration and initially drill out the "A" mounting hole. Install a 3/8 inch bolt, lock washer, and nut. Tighten the bolt enough so the mounting plate will hold position without slipping. Tape the alignment template to the radar. Using a small carpenter's level, rotate the mounting plate until the dotted line on the template is level. Drill out the "B" mounting hole.

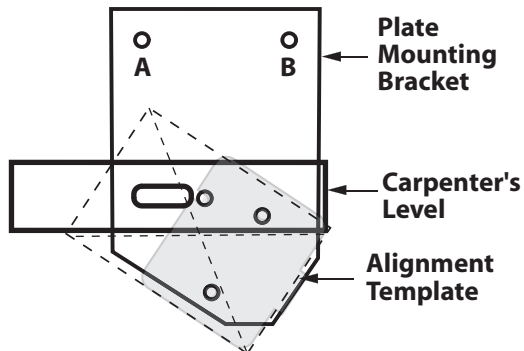

INSTALLATION INSTRUCTIONS



MOUNTING BRACKET TEMPLATE FOR PLATE

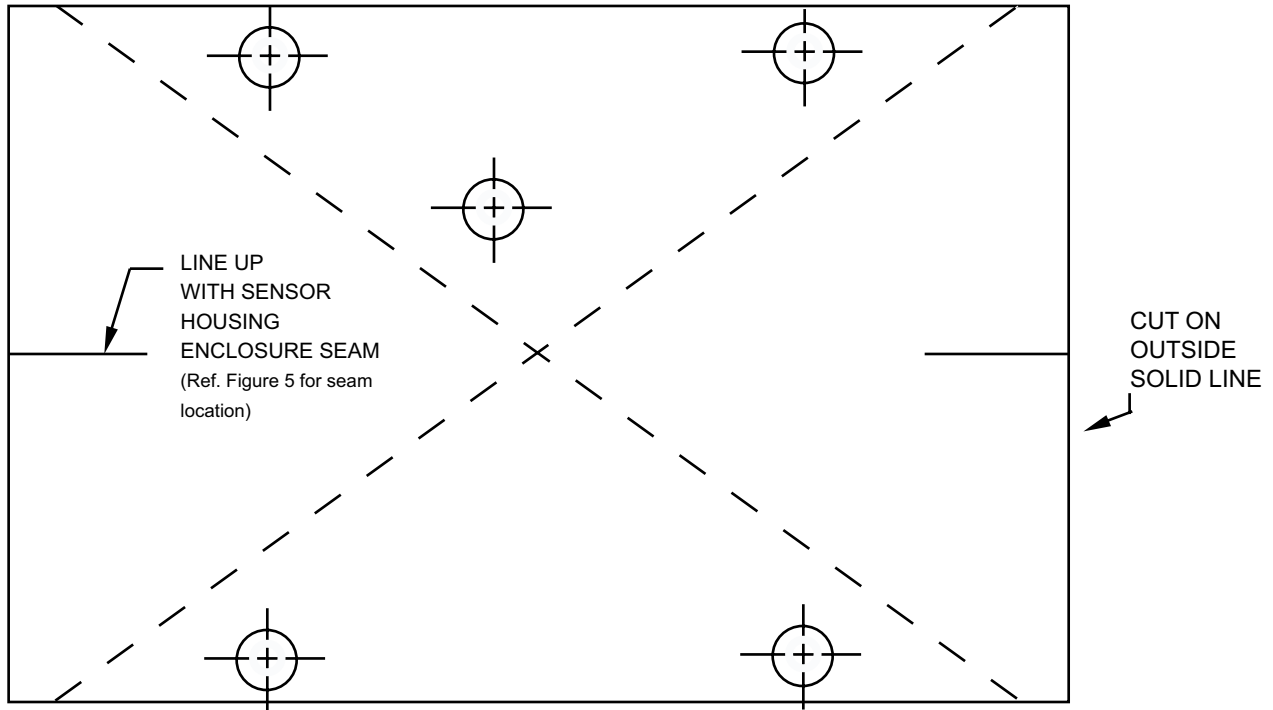

MOUNTING BRACKET TEMPLATE FOR PIPE

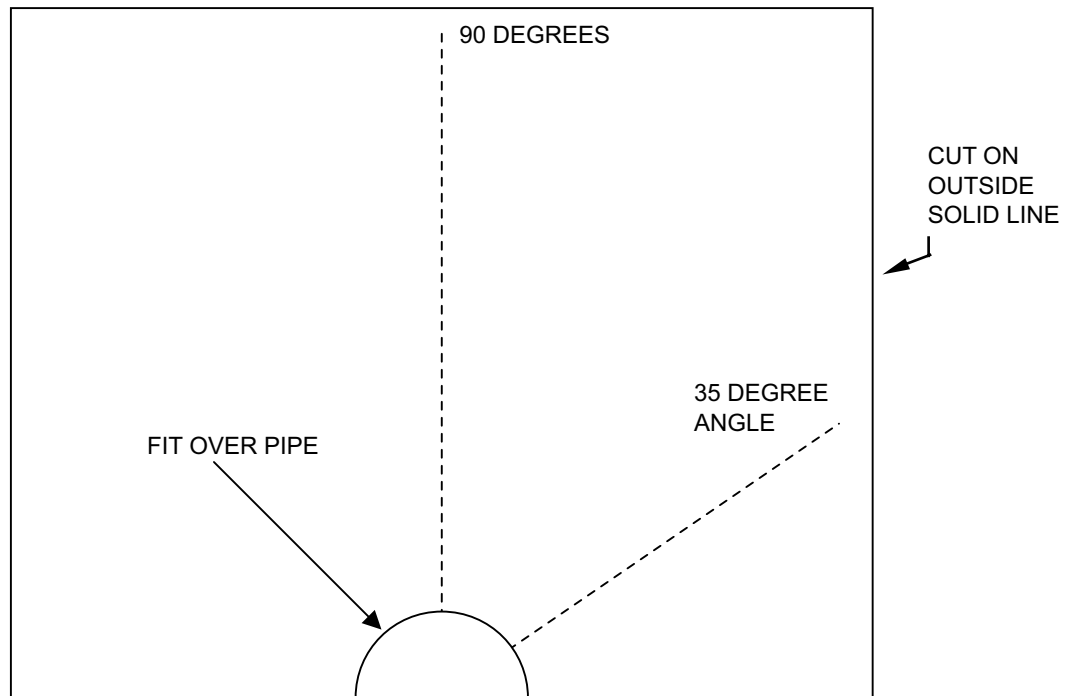

INSTALLATION INSTRUCTIONS



SAFETY INFORMATION

POWER - 12V VERSION

Voltage: 13.0V nominal (9.0 - 16.0V)
Current: Less than.60A

POWER - 24V VERSION (REQUIRES 24V DJ RVS III ADAPTER CABLE ASSEMBLY P/N 467830812)

Voltage: 26.0V nominal (18.0 - 32.0V)
Current: Less than.63A

ELECTRICAL PROTECTION

On both versions, power is to be supplied to the radar by a 5A automotive type fuse (or less) to protect the circuit. Reverse Polarity protection is built into the Radar using series diode (radar has open circuit to protect against reverse polarity on power lines).

SAFETY



The DICKEY-john RVS III Radar is an international radiator of RF energy. Although its radiated energy level is far below the limits set by En 61010-1: 1993 \ A2: 1995 - Chapter 12.4, it is advisable not to look directly into the face of the unit.

The radar must radiate toward the ground and at least 20 cm (8 inches) away from a human during use to comply with the RF human exposure limits as called out in FCC 47 CRFR sec. 2.1091. DO NOT mount the radar in a manner inconsistent with its defined use.

MAINTENANCE

The DICKEY-john RVSIII Radar requires no periodic maintenance. It has been designed to withstand typical environmental conditions found on the underside of an agricultural tractor or vehicle. If the radar is spray washed, do not exceed 65 Bars of pressure and maintain a distance of at least 1 meter.

MANUFACTURER

DICKEY-john Corporation
5200 Dickey-john Road
Auburn, Illinois 62615
Tel: (217) 438-3371
Fax: (217) 438-6012

EUROPEAN SUBSIDIARY

DICKEY-john Europe S.A.
165, Boulevard de Valmy
92706 Colombes, France
Tel: 33 1 41 19 21 80
Fax: 33 1 47 86 00 07

INSTALLATION INSTRUCTIONS



Dealers have the responsibility of calling to the attention of their customers the following warranty prior to acceptance of an order from their customer for any DICKEY-john product.

DICKEY-john[®] WARRANTY

DICKEY-john warrants to the original purchaser for use that, if any part of the product proves to be defective in material or workmanship within one year from date of original installation, and is returned to DICKEY-john within 30 days after such defect is discovered, DICKEY-john will (at our option) either replace or repair said part. This warranty does not apply to damage resulting from misuse, neglect, accident, or improper installation or maintenance. Said part will not be considered defective if it substantially fulfills the performance expectations. THE FOREGOING WARRANTY IS EXCLUSIVE AND IN LIEU OF ALL OTHER WARRANTIES OF MERCHANTABILITY, FITNESS FOR PURPOSE, AND OF ANY OTHER TYPE, WHETHER EXPRESS OR IMPLIED. DICKEY-john neither assumes nor authorizes anyone to assume for it any other obligation or liability in connection with said part and will not be liable for consequential damages. Purchaser accepts these terms and warranty limitations unless the product is returned within fifteen days for full refund of purchase price.



DICKEY-john[®]
CORPORATION

Revolutionizing Electronics

C.I.E. CHAMPION
INDUSTRIAL
EQUIPMENT

2855 Marleau Avenue, Suite A, Cornwall, Ontario K6H 7B6
Tel: 613 938-2900 Fax: 613 938-8219 1-800-267-9203
www.cie-eic.com