



Vickers

The Systemic Approach to Contamination Control

A Complete Guide for Maximum System Performance



Vickers Guide to Systemic Contamination Control

Contents

- 2 Vickers Systemic Contamination Control**
- 3 The Systemic Approach to Contamination Control**
- 3 Quantifying Fluid Cleanliness**
- 5 Sources of Contamination**
- 8 Damage Caused by Contamination**
- 16 Setting a Target Cleanliness Level**
- 18 Achieving Target Cleanliness**
- 22 Locating Contamination Control Devices**
- 27 Flushing New or Rebuilt Systems**
- 29 Confirming and Monitoring Achievement of Target Cleanliness**
- 31 ProActive Maintenance**

Vickers Systemic Contamination Control

Fluid Power is one of the most reliable and repeatable forms of power and motion control. All that is required is comprehensive state-of-the-art system design and modern systemic contamination control. When problems are encountered, 80% of the time they are related to inadequate contamination control practices. Understanding this handbook will greatly assist the design or maintenance engineer in achieving the balanced system cleanliness that is the cornerstone of fluid power reliability.

Vickers has a more than 75-year history of dedication to helping engineers develop, operate and maintain reliable, high quality power and motion control systems. This guide is only part of the package Vickers offers to enable the designer and user to achieve the most effective hydraulic power and motion control.

Introduction

For a hydraulic or oil lubricated machine, the development of a target cleanliness level and the plan to achieve it is as much a part of system design as the selection of the pump, valves, actuators or bearings. Unfortunately, when some system designers select a filter, they look no further than a filter manufacturer's catalog, with little regard for the particular system's total requirements. Proper selection and placement of contamination control devices in a system to attain the targeted cleanliness eliminates (the root cause of) up to 80% of hydraulic system failures. Additionally, the system cleanliness approach assures the user of the hydraulic system a cost-effective approach to contamination control that allows the price of the filters and elements to be quickly recovered by the savings of improved performance, increased component life, increased oil life, increased uptime and fewer repairs.

To stress the interacting relationship between component design, system design, filter performance and filter placement, Vickers has named our approach to filters and filtration Vickers Systemic* Contamination Control. This book is dedicated to defining the theory and practice of quality, cost-effective systemic contamination control.

***systemic** (sĭ-stēm' ĭk) adj.

1. Of or pertaining to a system or systems.

(American Heritage Dictionary, Houghton Mifflin Company.)

The Systemic Approach To Contamination Control

Working toward the most effective protection consistent with economy, we must first define our goal. In systemic contamination control the goal is always the same: to clean the fluid to the point that contamination is not a factor in the failure (catastrophic, intermittent, or degradation) of any component in the system during the desired useful life of that system. The first step towards this goal is the setting of a target cleanliness level that takes into account the specific needs of the system.

Once the target has been set, the next step is to select and position filters in the system so that the target can be achieved in a cost effective manner. This requires an understanding of filter performance, circuit dynamics and filter placement. While all three factors are important, the last two issues — circuit dynamics and filter placement — often receive much less attention than they require.

Today there are several sources for high efficiency filters that can initially keep the hydraulic or lubrication fluids clean. In most systems that have contamination problems, the cause is either poorly conceived filter placement, because of a lack of understanding of the dynamics of fluid flow, or the inability of the filter elements to maintain their performance levels throughout their service life in the system. The engineering guidelines needed to deal with both filter placement and system dynamics are presented in this document.

After the machine is in operation, the last and ongoing step is to confirm that the target cleanliness level is being maintained. This is most often accom-

plished by sending a fluid sample to a particle counting laboratory that gives cleanliness code data to established standards. If the target is being met, the system only needs to have filters maintained and the fluid retested periodically. If the cleanliness target is not being achieved, corrective actions need to be taken. Sometimes a change in maintenance practices is needed, but at other times a shift to a finer grade of filter elements or additional filter housings may be needed. Intelligent consideration of contamination control during the design phase is the best way to avoid both short- and long-term problems and gain the assurance that each hydraulically powered or oil lubricated machine will give long, reliable service.

Quantifying Fluid Cleanliness

The first step in setting a target cleanliness level is to understand that “cleanliness” is not a general term but rather a specific quantitative value. The current international standard for cleanliness of a hydraulic or lubricating fluid is defined by ISO 4406. Using an approved laboratory particle counting procedure, the number and size (in micrometers) of solid particles in a milliliter of fluid is determined.

Typical data from a hydraulic fluid sample counted by an automatic particle counter is:

Particles Size 'X' in Micrometers	Number of particles greater than 'X' size in one ml of test fluid
2µm	5120
5µm	89
10µm	43
15µm	22
25µm	3
50µm	.4

(Note: Particle counts are normally run on 10 to 100 milliliters of fluid and then factored to report results for 1 milliliter. This is the reason results of fractional particles can be reported.)

Vickers Systemic Approach to Contamination Control

- Set a target Cleanliness Level
- Select filters and filter placements to achieve target
- Sample fluid and confirm achievement

Automatic Particle Counting

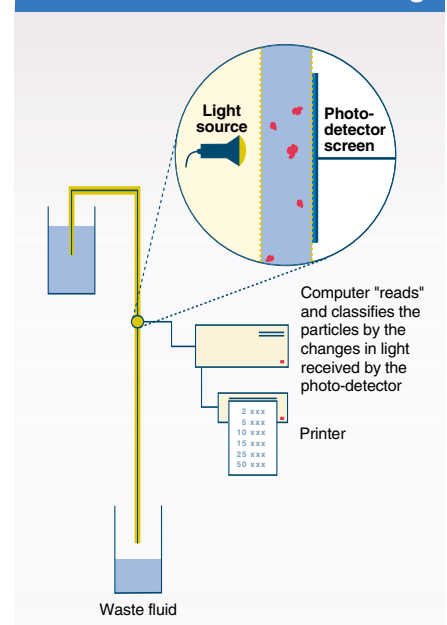

Cleanliness Code Chart

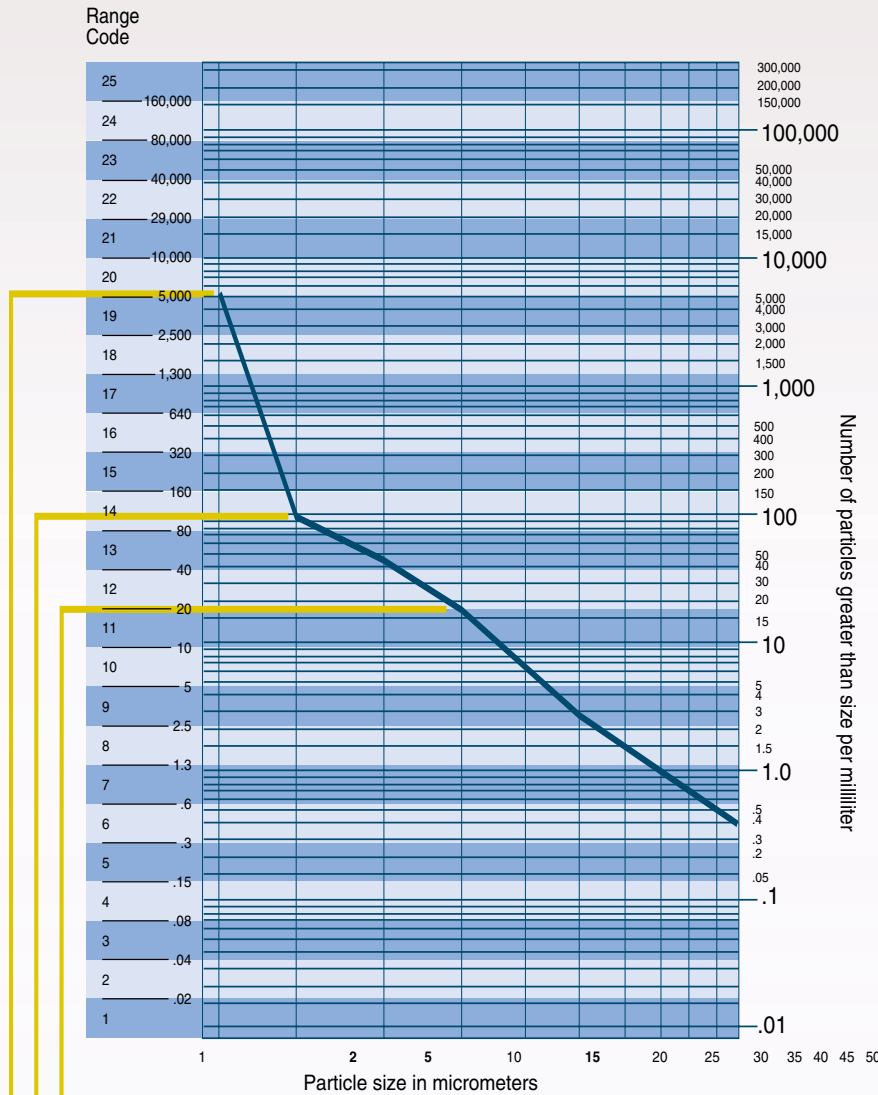

20/14/12
Cleanliness Code

Example	Particle size "X" in micrometer	Number of particles greater than "X" size in one ml of test fluid	Range code
	2	5120	20
	5	89	14
	10	43	X
	15	22	12
	25	3	X
	50	.4	X

Once the results are obtained, the points are plotted on a Cleanliness Chart. This chart has range codes (far left edge) that give a number, 0 through 25, that corresponds to a specific number of particles. Taking the range code for the number of 5µm and larger particles and the range code for the number of 15µm and larger particles and combining them together with a slash (/) gives us the ISO Cleanliness Code for that fluid. For the particle count in the example, the 89 particles of 5µm and larger size are in the 14 range and the 22 particles of 15µm and larger is in the 12 range. This means the example fluid is described as a **ISO 14/12** cleanliness fluid.

Unfortunately, the current ISO standard does have a weakness in that it can mask a significant build-up of very fine silt sized particles by the non-reporting of the counts smaller than 5µm. To remedy this, Vickers has adopted, and ISO is considering, expanding the code to three ranges correlating to 2µm, 5µm and 15µm. For the example presented, the Cleanliness Code becomes **20/14/12**. Throughout this Vickers document we will show cleanliness codes with 3 ranges, the last two being bold type to signify that they are the current ISO standard.

Sources of Contamination

There are four primary sources for solid contamination to enter a hydraulic fluid. They are: contaminated new oil, built-in contamination, ingressed contamination and internally-generated contamination. Each of these sources needs to be understood as each is a major consideration in filter placement.

Contaminated New Oil

Although hydraulic and lubrication fluids are refined and blended under relatively clean conditions, the fluid travels through many hoses and pipes before it is stored in drums or in a bulk tank at the user's facility. At this point, the fluid is no longer clean as the fluid lines it has traveled through have contributed metal and rubber particles, and the drums have added flakes of metal or scale. Storage tanks are a real problem because water condenses in them causing rust particles. Contamination from the atmosphere can also find its way into the tank unless satisfactory air breathers are fitted.

If the fluid is stored under reasonable conditions, the principal contaminants on delivery to the machine will be metal, silica and fibers. With fluids from reputable suppliers, sampling has shown typical Cleanliness Levels of 17/16/14 or dirtier. Using a portable transfer cart fitted with a high efficiency filter, contamination should be removed from new fluids before the contamination enters and damages the components in the system.

Sources of Contamination

- Contaminated New Oil
- Built-in Contamination
- Ingressed Contamination
- Internally Generated Contamination

Dirty New Oil

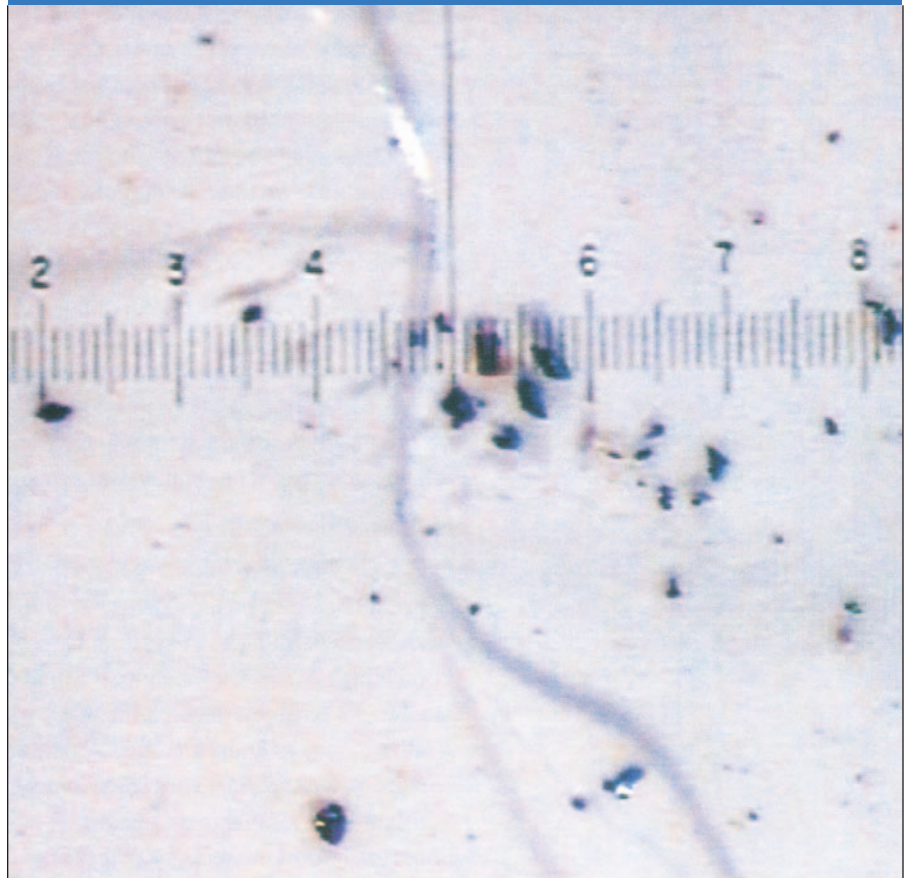

Contamination particles found in new fluid include rust, scale, fibers and sand (photomicrograph at 100x).

Sources of Ingressed Contamination

- Reservoir Vent Ports
- Power Unit Access Plates
- Maintenance Events
- Cylinder Rod Seals

Built-in Contamination

New machinery always contains a certain amount of built-in contamination. Care in system assembly and in new component flushing reduces this but never eliminates it. Typical built-in contaminants are burrs, chips, flash, dirt, dust, fiber, sand, moisture, pipe sealant, weld splatter, paint and flushing solution.

The amount of contamination removed during the system flush depends not only on the effectiveness of the filters used, but also the temperature, viscosity, velocity and “turbulence” of the flushing fluid. Unless high velocities and turbulence are attained, much of the contamination will not be dislodged until the system is in operation, with catastrophic component failure a possible result. Irrespective of the standard of flushing executed by the machine builder, an off-load period of “running-in” should be regarded as essential for any new or rebuilt hydraulic or lubrication system.

Ingressed Contamination

Contamination from the immediate surroundings can be ingressed into the fluid power or lubrication system. On large installations, such as those within steelworks or automotive plants, it is relatively easy to know the environmental conditions, though they vary considerably. For example, a coke oven system operates in conditions very different from a similar system in a cold mill. For mobile equipment, there is a very wide variation in environmental conditions by application, location and even by weather conditions (i.e. high winds).

The key is to severely limit the access environmental contamination has to enter the hydraulic or lubrication system. There are four major ways dirt can enter a system: reservoir vent ports

(breathers), power unit or system access plates, components left open during maintenance and cylinder seals.

Sources of Ingressed Contamination

RESERVOIR VENT PORTS allow air exchange into and out of the reservoir to compensate for changes in fluid level caused primarily by cycling cylinders and thermal expansion and contraction of the fluid. All vents that exchange air need to be fitted with barrier-type air breather filters. Other acceptable options are to use bladders or flexible rubber barriers to prevent the exchanged air from coming in contact with the surface of the system fluid or valving which prevents air changes while allowing relief protection against over-pressurizing the reservoir.

POWER UNIT ACCESS PLATES — In some plants it cannot be assumed that access plates will always be replaced, though this problem is not as common as it once was. Good systemic contamination control requires that reservoirs are designed to remain sealed during operation and any access plates that need to be removed during maintenance be easy to reinstall. The most important factor in this aspect of contamination control is the proper education of all maintenance and service personnel.

INGRESSION DURING MAINTENANCE —

Whenever a system is opened for maintenance, there is an opportunity for environmental contamination to enter the system. All possible care should be taken to ensure that open ports are kept covered or plugged, and component disassembly and rework is done in an area that is protected from excessive airborne dirt and contamination.

Lint free rags and oil absorbent materials in “socks” (rather than loose glandular form) should be used for component wipedown and area clean up.

CYLINDER SEAL INGRESSION — Rod wiper seals rarely are designed to be 100% effective in removing the thin oil film and the fine contamination from the cylinder rod. Environmental dirt that sticks to an extended rod is drawn back into the cylinder and washed off into the system fluid. Every effort should be made during machine design to avoid dirt or other contaminants from landing directly on extended cylinder rods. When this is unavoidable, the filters should be positioned and sized to capture this abundance of dirt.

Generated Contamination

The most dangerous contamination to a system is the contamination generated by the system itself. These particles are “work hardened” to a greater hardness than the surface from which they came, and are very aggressive in causing further wear in the system. In a system running on properly cleaned fluid very few particles are generated, although all components (especially pumps) create a small amount of particles during routine operation. In a system where these particles are not quickly captured the elevated contamination levels will cause the number of additional generated particles to increase at a highly accelerated rate! The best way to prevent contamination generation within a system is to start with a clean (fully flushed) system and keep the system fluid clean.

Generated Contamination

Abrasive Wear — Hard particles bridging two moving surfaces, scraping one or both.

Adhesive Wear — Loss of oil film allows metal to metal contact between moving surfaces.

Fatigue Wear — Particles bridging a clearance cause a surface stress riser or microcrack that expands into a spall due to repeated stressing of the damaged area.

Erosive Wear — Fine particles in a high speed stream of fluid eat away a metering edge or critical surface.

Cavitation Wear — Restricted inlet flow to pump causes fluid voids that implode causing shocks that break away critical surface material.

Aeration Wear — Air bubbles in the fluid implode breaking away surface material.

Corrosive Wear — Water or chemical contamination in the fluid causes rust or a chemical reaction that degrades a surface.

Sources of Contamination

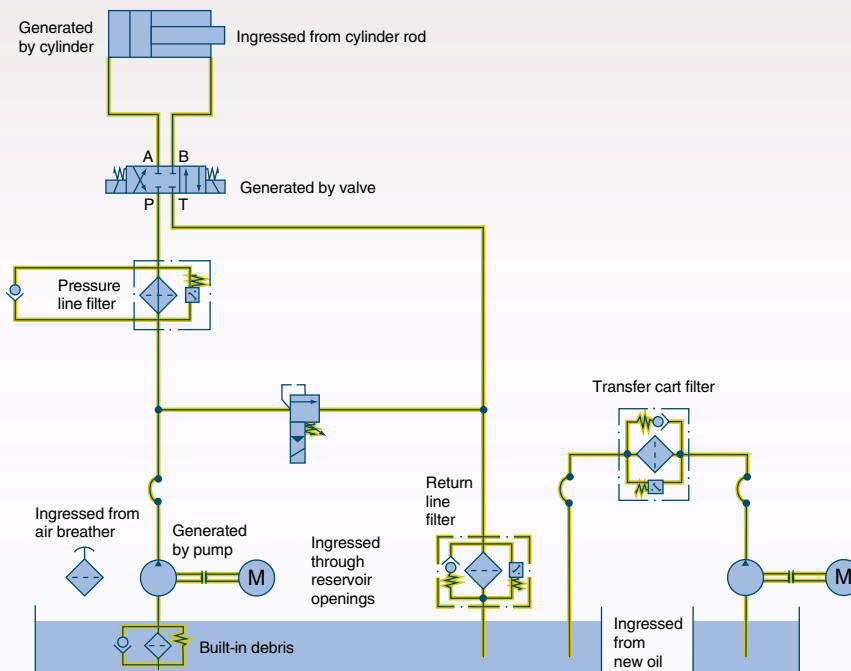

Note: Suction strainers with bypass are shown as an option in many examples in this book. See page 24 for a discussion on their application.

Damage Caused by Contamination

Types of Failures

- Catastrophic Failure
- Intermittent Failure
- Degradation Failure

Contaminant particles come in all shapes and sizes and are made up of a wide variety of materials. The majority are abrasive, so when they interact with surfaces they plough and cut fragments from critical surfaces in the components. This abrasive wear and surface fatigue accounts for almost 90% of degradation failures.

Types of Failures

Failures arising from contamination fall into three categories:

1. **CATASTROPHIC FAILURE** occurs when a large particle enters a pump or valve. For instance, if a particle causes a vane to jam in a rotor slot, the result may well be complete seizure of the pump or motor. In a spool type valve, a large particle trapped at the wrong place can stop a spool from closing completely. Another example of catastrophic failure occurs when the pilot orifice of a valve is blocked by a large particle. Fine particles can also cause catastrophic failure; a valve, for example, can fail to operate due to silting.

2. **INTERMITTENT FAILURE** can be caused by contamination on the seat of a poppet valve which prevents it from reseating properly. If the seat is too hard to allow the particle to be embedded into it, the particle may be washed away when the valve is opened again. Later, another particle may again prevent complete reclosure and be washed away. Thus, a very annoying type of intermittent failure occurs.

3. **DEGRADATION FAILURE** can be the result of abrasive wear, corrosion, cavitation, aeration, erosion or surface fatigue. Each one causes increased internal leakage in the system components which reduces its efficiency or accuracy, but these changes are initially difficult to detect. The eventual result, particularly with pumps, is likely to be catastrophic failure. The particles most likely to cause wear are clearance-size particles which just bridge the critical clearances between moving surfaces in the component. Oil also suffers degradation due to the presence of excessive contamination.

Sizes of Critical Clearances

Manufacturing clearances within hydraulic components can be divided into two principal zones, i.e. up to 5 micrometers for high pressure components and up to 20 micrometers for lower pressure components. The actual operating clearances for a component are set by the type of component and operating conditions it sees. These clearances help to define the cleanliness of the fluid required by that component.

Interaction of Moving Parts

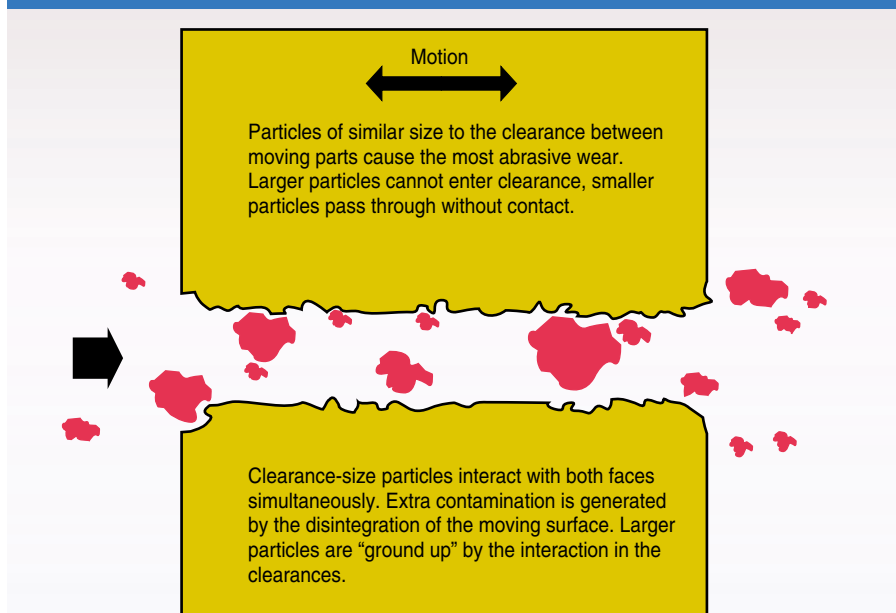

Mechanism of Fatigue

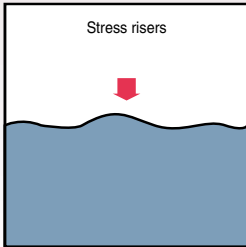

1. First, stresses at component surface develop and lead to elastic deformation and plastic flow of material.

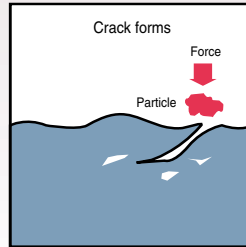

2. Then, small surface micro cracks develop at or just beneath the solid surface during component use.

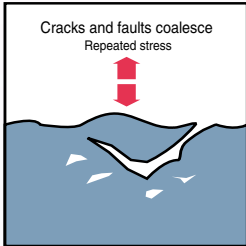

3. The faults then join to form larger voids undermining component surface.

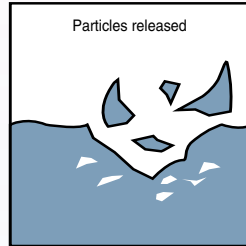

4. Surface material then breaks away.

Erosive Wear

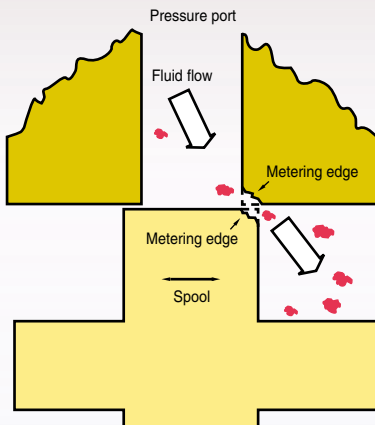

The metering edge of the spool and valve land has been eroded away by the particles in the high velocity fluid flowing through the valve.

Pumps

All hydraulic pumps have component parts which move relative to one another, separated by a small oil filled clearance. Generally these components are loaded toward each other by forces related to area and system pressure.

Since the life of most pumps is determined by a very small quantity of material being removed from a few surfaces, it follows that rapid degradation and eventual seizure will occur if the fluid within the clearance is heavily contaminated. The design of low pressure units permits relatively large clearances and typically only larger ($10\mu\text{m}$ and larger) contamination has a significant damaging effect. Also at the lower pressure, there is less force available to drive particles into critical clearances. Increasing or pulsating the pump pressure is of major significance in determining the effect of contamination on a pump.

Another factor affecting clearances is the oil film thickness, which is also related to fluid viscosity (film strength). An optimum viscosity value is used during design. The oil should provide good film thickness to support loads hydrodynamically, and also be thin enough to allow adequate filling of the pump without cavitation. It is generally found in practice that critical clearances are larger where higher viscosities are used, and for this reason the maximum viscosity which is compatible with the inlet conditions should be chosen. Similarly, good fluid temperature control is beneficial in this respect.

The areas in pumps particularly subject to critical clearance wear problems are:

Vane pump – Vane tip to cam ring, rotor to side plate, vane to vane slot.

Gear pump – Tooth to housing, gear to side plate, tooth to tooth.

Axial piston pump – Shoe to swash plate, cylinder block to valve plate, piston to cylinder block.

In many of these cases, the clearances are effectively self-adjusting under operating conditions, i.e. with increasing pressure clearances becoming smaller. Under adverse conditions, and particularly where there is shock loading, there is an increased vulnerability to smaller sized contamination particles. Even where clearances are nominally fixed, components under high loads may take up eccentric positions which again make them vulnerable to smaller particles.

From engineering data and field experience, Vickers has set recommended contamination levels which, if achieved, will result in an increased life for most systems and components. These are presented in the next section, which deals with setting target cleanliness levels.

The useful life of a pump ends when it no longer delivers the required output at a given shaft speed. All too often, degradation goes undetected until finally catastrophic failure occurs, with vast quantities of contamination being released into the system. Following such a failure, the life of the replacement pump will be greatly reduced if the system is not properly cleaned or protected.

To the end user, total cost is the most important issue; the failure of a low-cost pump may well result in expensive downtime and maintenance. If, by the inclusion of the proper contamination control devices, such a failure can be avoided, the initial investment in such devices is fully recovered.

Critical Clearances in a Vane Pump

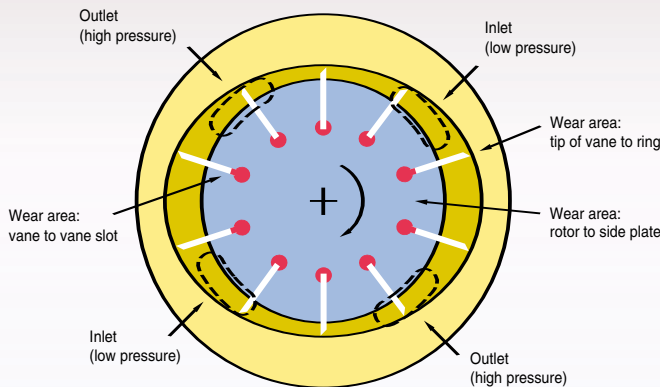

Critical Clearances in a Gear Pump

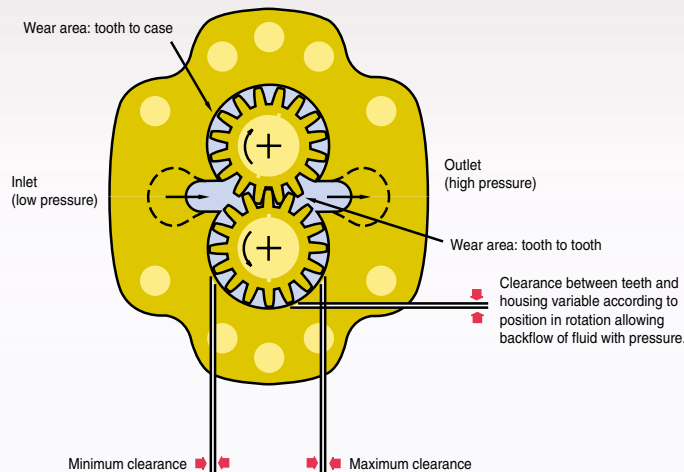

Motors

What has been written about pumps applies generally to motors because of their similar design. It must be remembered that a majority of the contaminant passing through the pump will also reach the motor where it will cause a similar performance degradation. If, for example, due to wear, the volumetric efficiency of the pump falls to 85% of its original value and the volumetric efficiency of the motor falls to 90% of original, then the overall volumetric efficiency of the pump and motor will drop to $0.85 \times 0.9 = 76.5\%$ of the original value.

Hydrostatic Transmission

Hydrostatic transmissions most often consist of a servo controlled pump and a fixed volume motor. Wear to a critical

surface in any component will degrade the overall performance of the transmission. Failure of a component can spread debris throughout the system causing extensive and expensive secondary damage. High efficiency filtration is a key factor in achieving long, reliable service from a closed loop hydrostatic transmission.

Directional Valves

In most directional valves, the radial clearance specified between bore and spool is between 4 to 13 micrometers. As is well known, the production of perfectly round and straight bores is exceptionally difficult, so it is unlikely that any spool will lie exactly central in the clearance band. In a CETOP 3 valve, a spool is likely to have less than 2.5 micrometers clearance.

Critical Clearances in an Axial Piston Pump

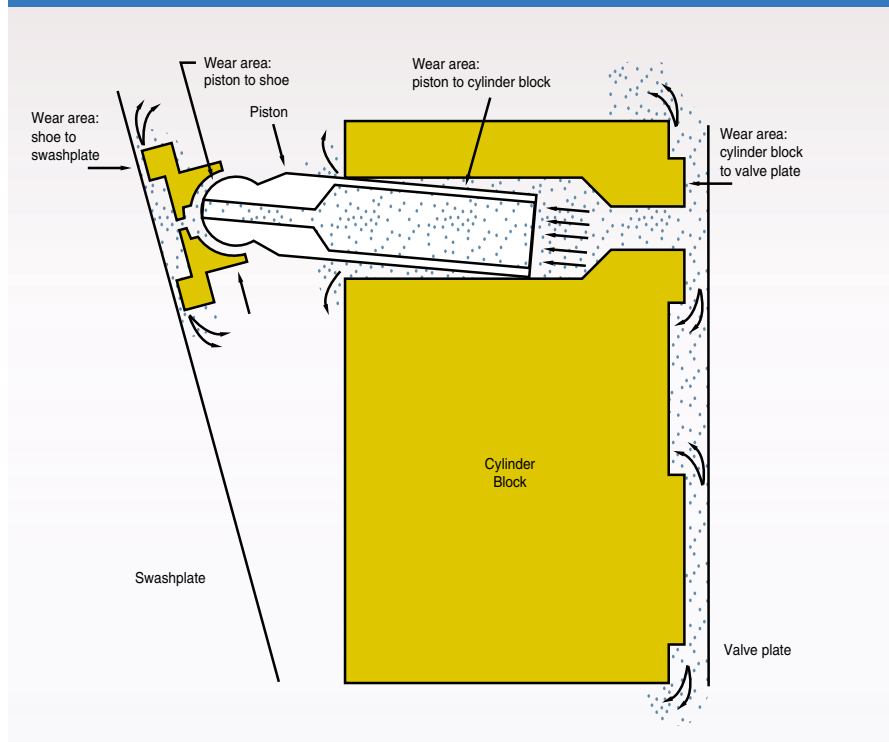

In an electrically operated valve, the forces acting on the solenoid are: flow forces, spring forces, friction forces and inertia forces.

Flow, spring and inertia forces are inherent factors, but friction forces are to a great extent dependent on system cleanliness. If the system is heavily contaminated with particles similar in size to the radial and diametrical clearances, higher forces will be needed to move the spool.

An even worse situation results from silting, where contaminant is forced into

the clearances under pressure, eventually leading to breakdown of the oil film and spool binding.

This situation occurs when valves subjected to continuous pressure are operated infrequently. Such valves should preferably have local filtration of a high efficiency in the pressure line, but due account should be taken of possible pressure surges generated during component operation. The use of filters as a special protection for single units or groups of units can result in the need for a large filter element of high capacity, if the general cleanliness level in the system is poor.

Some idea of the forces needed to break this spool binding, compared with the force available from the solenoid, can be gained from the example of a CETOP 3 valve operating at 3000 psi (210 bar). If a valve of this type remains in the spring offset or energized position for a lengthy period of time, silting takes place between spool and bore and can cause total immobility. The force needed to overcome this state has been found through experiments to be approximately 30 pounds, but both spring and solenoid are designed to exert only 10 pounds. The effect of the excessive silting can be total system failure.

Valve Spool Critical Clearance

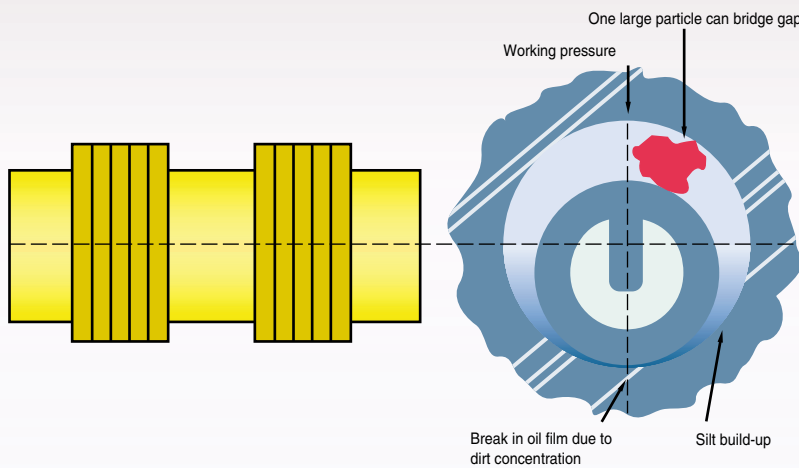

Valve Spool Clearances (with flows and forces)

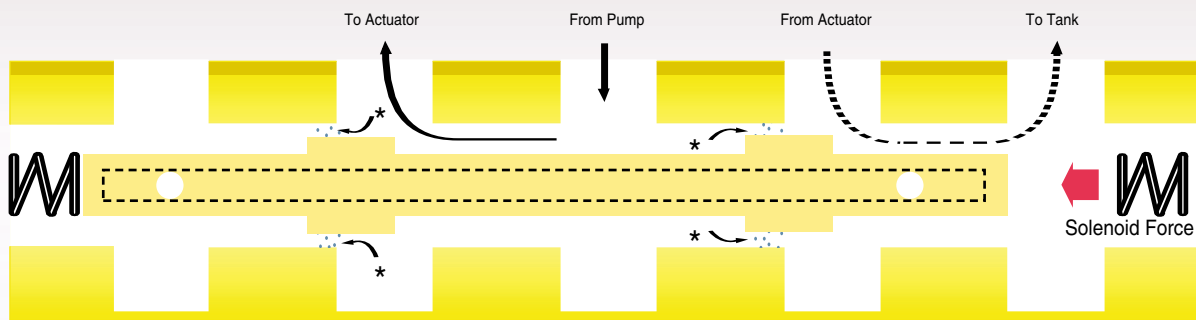

*Silt collects in tight clearance leak paths causing increased resistance to shifting

Pressure Controls

Abrasive particles in high velocity streams of oil erode internal surfaces. This situation is common to pressure controls, particularly relief valves which are subjected to maximum system pressure drop. Pilot control stages generally see low volumes at high velocities, and heavy contamination affects both their stability and repeatability.

Flow Controls

The contamination tolerance of flow control valves will depend very much on the orifice configuration. Two different orifices which are of entirely different shape can have equal areas. The groove type will tolerate a high contamination level, except when used at low setting, whereas a flat cut orifice is much more prone to silting at all settings.

With all types of pressure compensated flow controls, the performance of the pressure reducing element can be considerably affected by contamination, irrespective of valve setting. Damage to the metering orifice can also occur, which will become particularly apparent at lower settings.

Generally speaking, all spool-type control valves are affected by contamination in the system, especially at high pressures. The effects are likely to be magnified if precise axial positioning of the spool is necessary as, for example, in pressure reducing valves where limited forces are available to operate the spool. On the other hand, poppet valves, though affected by large particles of contamination, tend to be far more tolerant of silt due to the self-cleaning action of the seat. However, erosion of critical seat surfaces must be avoided.

Flow Control Valve Throttle Sections

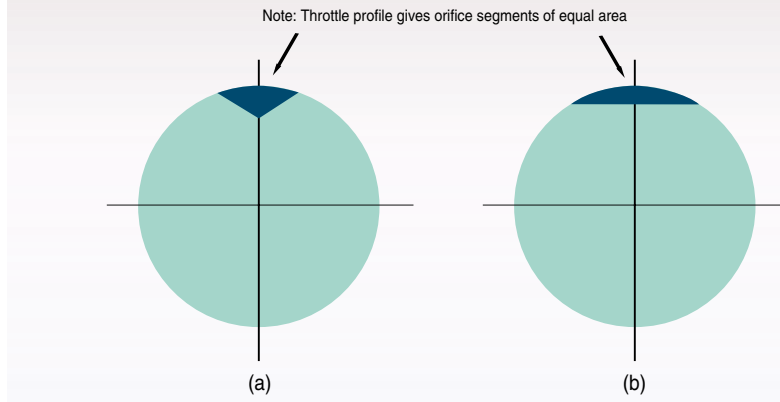

Bearing Wear

Typical clearance between the rolling elements of a bearing and the outer and inner race can be less than $2\mu\text{m}$. Particles in the lubrication fluid are rolled into this critical clearance causing a surface micro crack, initiating the spalling process.

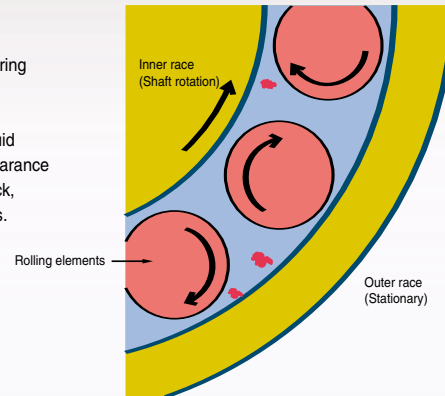

Bearings

In both rolling and sliding contact bearings, a thin oil film separates the ball from the race or the journal surfaces from the shaft. As long as there is no direct contact between the moving parts, the expected fatigue life of the bearing approaches infinity. The most common way for direct contact to happen is to have a particle bridge the oil film and contact a moving and stationary surface at the same time. The resulting damage is often a scratch or surface crack that initiates the spalling process. In most bearings, particles as small as $3\mu\text{m}$ can have a negative impact on the life of the bearing or system.

Piston/shoe Subassembly



Piston head contamination damage — Shoes can also become loose on the piston head as a result of severe scoring and pitting from contamination.

Ruined Pistons

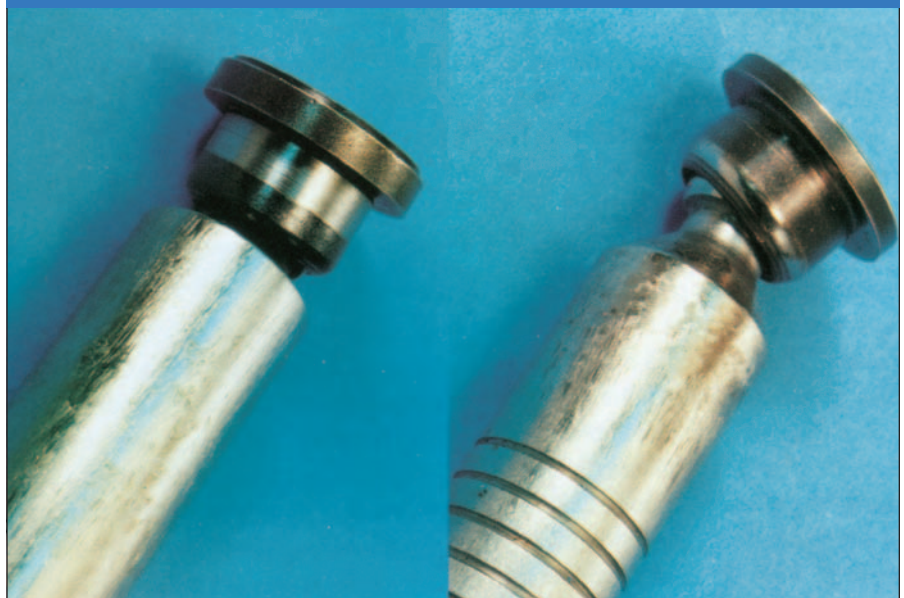

Telltale effects of contamination and seizing on the piston diameter can be seen in these photos. Pistons in this condition cannot be reworked.

Examples of Wear on Actual Vickers Components

Vickers guide to Pump Failure Analysis contains many examples of failures caused by contamination. Typical contamination damage to a piston/shoe, piston and cylinder block is shown here.

Summary

As explained above, an individual large particle arriving at the wrong place at the wrong time can cause catastrophic failure. A small quantity of silt-sized particles can also cause problems by eroding a surface or by building up in a critical area.

Surfaces within components are designed to be separated by an oil film, the thickness of which may be continually changing. When this gap is bridged by

contaminants, wear will occur, thereby generating further particles which may be ground into many more smaller particles. Fine particles, individually or in small quantities, may not cause damage. But if present in slightly higher concentrations, they can lead to failure through silting.

Piston Pump Failures—Cylinder Block

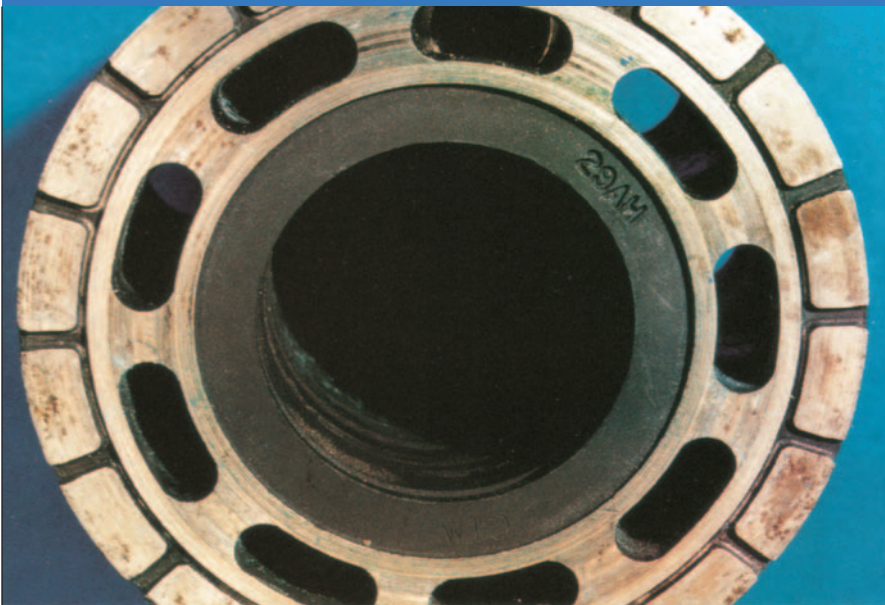

The individual cylinder bores within a cylinder block are prone to excessive wear and tear. This can be due to dry run, lack of lubricity in the fluid or contaminants. Cylinder blocks with worn or scored bores should never be reused.

The top surface of a cylinder block that contacts the valve plate can also become scored or pitted due to improper operating conditions such as aeration, cavitation, contamination and high system temperature.

Setting a Target Cleanliness Level

Setting a Target Cleanliness Level

- Determine the cleanliness recommended for the most sensitive component in system
- Adjust code for fluid type
- Adjust code for external factors that increase the stress on the system components

As stated previously, all hydraulic and lubrication systems should have a target cleanliness level for that specific system clearly stated in their engineering documentation. This target should be set after considering the components in the system (including the fluid), the typical operation and start-up temperatures, the duty cycle, the systems' required useful life and safety issues. As the actual cleanliness level of the fluid varies by sampling point within the system (i.e. reservoir, pressure line, return line, etc.), the target cleanliness level is assumed to be set for the return line upstream of the return line filter, unless stated otherwise.

In 1976, Vickers first issued a chart giving suggested minimum cleanliness levels for acceptable component life. This graph has been the basis for much that has been written and learned since its publication.

The following chart and procedure have been prepared to help design and maintenance engineers set a target cleanliness level. The cleanliness level recommendations are based on engineering evaluations (including materials, critical clearances and machining tolerances) and practical field experiences with Vickers and other brands of hydraulic or load bearing components.

Suggested Cleanliness Level for Good Component Life (circa 1976)

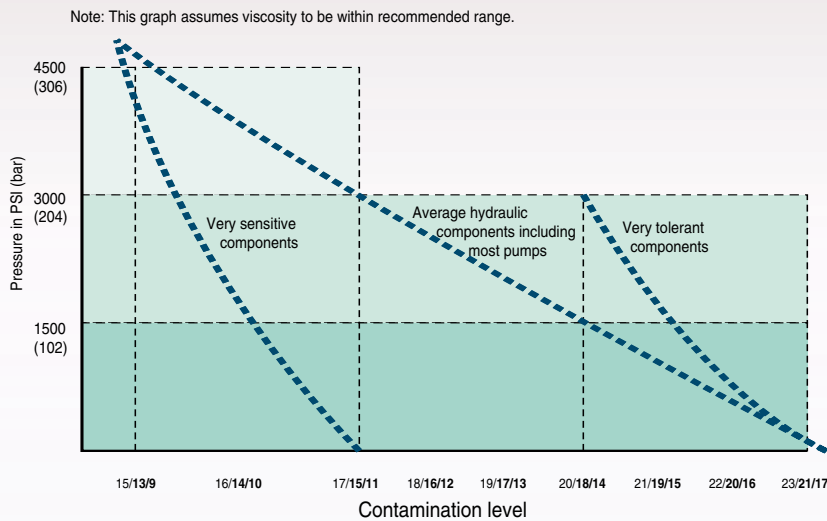

Note: Graph modified to show 3 code cleanliness levels corresponding to the earlier ISO cleanliness codes.

Note: Vickers components are designed and manufactured to high standards that maximize their dirt tolerance. Special materials, surface preparations, and flow paths are utilized to ensure reliable operation. However, Vickers and all other brands of components operate best on properly cleaned fluids. Vickers has prepared these recommendations to help users of hydraulic and oil lubricated machines maximize the in-service life of their individual components and the total system. These recommendations are more valuable than traditional recommendations that focus on the maximum allowable dirt rather than the cleanliness needed for long, trouble free operation.

Vickers Recommended Cleanliness Code Chart			
PUMPS			
Pressure	< 2000 PSI < 140 Bar	< 3000 PSI 210 Bar	< 3000 PSI > 210 Bar
Fixed Gear	20/18/15	19/17/15	18/16/13
Fixed Vane	20/18/15	19/17/14	18/16/13
Fixed Piston	19/17/15	18/16/14	17/15/13
Variable Vane	19/17/15	18/16/14	17/15/13
Variable Piston	18/16/14	17/15/13	16/14/12
VALVES			
Pressure		3000 PSI 210 Bar	> 3000 PSI > 210 Bar
Directional (solenoid)		20/18/15	19/17/14
Pressure (modulating)		19/17/14	19/17/14
Flow Controls (standard)		19/17/14	19/17/14
Check Valves		20/18/15	20/18/15
Cartridge Valves		20/18/15	19/17/14
Screw-in Valves		18/16/13	17/15/12
Prefill Valves		20/18/15	19/17/14
Load-sensing Directional Valves		18/16/14	17/15/13
Hydraulic Remote Controls		18/16/13	17/15/12
Proportional Directional (throttle) Valves		18/16/13	17/15/12*
Proportional Pressure Controls		18/16/13	17/15/12*
Proportional Cartridge Valves		18/16/13	17/15/12*
Proportional Screw-in Valves		18/16/13	17/15/12
Servo Valves		16/14/11*	15/13/10*
ACTUATORS			
Pressure	< 2000 PSI < 140 Bar	3000 PSI 210 Bar	> 3000 PSI > 210 Bar
Cylinders	20/18/15	20/18/15	20/18/15
Vane Motors	20/18/15	19/17/14	18/16/13
Axial Piston Motors	19/17/14	18/16/13	17/15/12
Gear Motors	21/19/17	20/18/15	19/17/14
Radial Piston Motors	20/18/14	19/17/15	18/16/13
Swashplate Design Motors	18/16/14	17/15/13	16/14/12
HYDROSTATIC TRANSMISSIONS			
Pressure	< 2000 PSI < 140 Bar	3000 PSI 210 Bar	> 3000 PSI > 210 Bar
Hydrostatic Transmissions (in-loop fluid)	17/15/13	16/14/12*	16/14/11*
BEARINGS			
Ball Bearing Systems	15/13/11*		
Roller Bearing Systems	16/14/12*		
Journal Bearings (high speed)	17/15/13	>400 RPM	
Journal Bearings (low speed)	18/16/14	<400 RPM	
General Industrial Gearboxes	17/15/13		

*Requires precise sampling practices to verify cleanliness levels.

How to Set a Target Cleanliness Level

STEP ONE

Using Vickers Recommended Cleanliness Code Chart, determine the cleanest fluid (lowest code) required by any component in the system. All components that draw fluid from a common reservoir should be considered to be part of the same system even if their operations are independent or sequential (i.e. a central power unit running several different machines). The pressure rating for the system is the maximum system pressure achieved by the machine during a complete cycle of operation.

STEP TWO

For any system where the fluid is not 100% petroleum oil, set the target one Range Code cleaner for each particle size.

Example: If the cleanest code required was 17/15/13 and water glycol is the system fluid, the target becomes 16/14/12.

STEP THREE

If any two or more of the following conditions are experienced by the machine or system, set the target cleanliness one level lower for each particle size.

- Frequent cold starts at less than -18°C (0°F)
- Intermittent operation with fluid temperatures over 70°C (160°F)
- High vibration or high shock operation
- Critical dependence on the system as part of a process operation

Looking at the example above, if this system was expected to cold start and a failure could stop all production, the target cleanliness would become 15/13/11.

Using this three-step procedure the system target cleanliness code for the system is now set.

Achieving Target Cleanliness

Achieving System Cleanliness

- Select a filter with $Bx = > 100$ performance
- Select a filter with high strength under system stress
- Locate the filters so that they see sufficient system flow to capture the contamination
- Select a filter which will provide long in-service life

There are four major factors in positioning contamination control devices in a hydraulic or lubrication system to achieve a target cleanliness level. They are:

- Initial filter element efficiency
- Filter element efficiency under system stress
- Location and sizing of contamination control devices in the system
- Filter element service life of the system

Filter Element Initial Efficiency

The international standard for rating the efficiency of a hydraulic or lubrication filter is the Multipass Filter Performance Beta Test (ISO 4572). The results of this test are reported as a ratio of number of particles greater than a designated size upstream of the test filter compared with the number of same size particles downstream of the test filter. These results are then expressed as a Beta ratio.

Multipass testing has greatly aided engineers in the development of better and more efficient filter elements, and it has helped the design engineer who needed to specify a filter element's performance. But, there's little correlation between multipass efficiencies and system cleanliness needs. In the final performance analysis, the goal is properly cleaned fluid and not just very high Beta ratios and dirt capacity. The most important information needed by a designer or user of a hydraulic system is

Filter Ratings

Nominal Filtration Rating

Absolute Filtration Rating

Filtration Ratio (Beta)

Nominal Rating—An arbitrary micrometer value indicated by the filter manufacturer. Due to lack of reproductivity, this rating is deprecated.

Absolute Rating—The diameter of the largest hard spherical particle that will pass through a filter under specified test conditions. It is an indication of the largest opening in the filter element.

Filtration Ratio (β_n)—The ratio of the number of particles greater than a given size upstream of the test filter divided by the number of particles of the same size downstream of the test filter.

Beta Ratios and Corresponding Efficiencies

Beta Ratios	Efficiency
1	0%
2	50.00%
5	80.00%
10	90.00%
20	95.00%
75	98.70%
100	99.00%
200	99.50%
1000	99.90%
5000	99.98%

Beta ratios and dirt capacity are only a guide to system cleanliness needs.

The Multipass Filter Performance Test

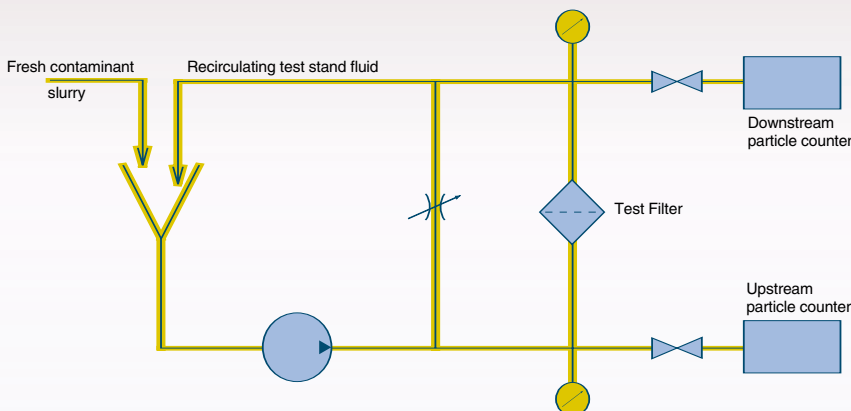

the system cleanliness they can expect when that filter and media are properly installed in the system.

Each grade of Vickers high efficiency filter media construction is thoroughly multipass tested and then rated with the system cleanliness level expected to be achieved with the use of that product. The assumptions behind these cleanliness ratings are: 1) the filter sees full

system flow, 2) the filter is the primary filter in the system, and 3) air breathers along with recognized maintenance practices will limit dirt ingress from the atmosphere.

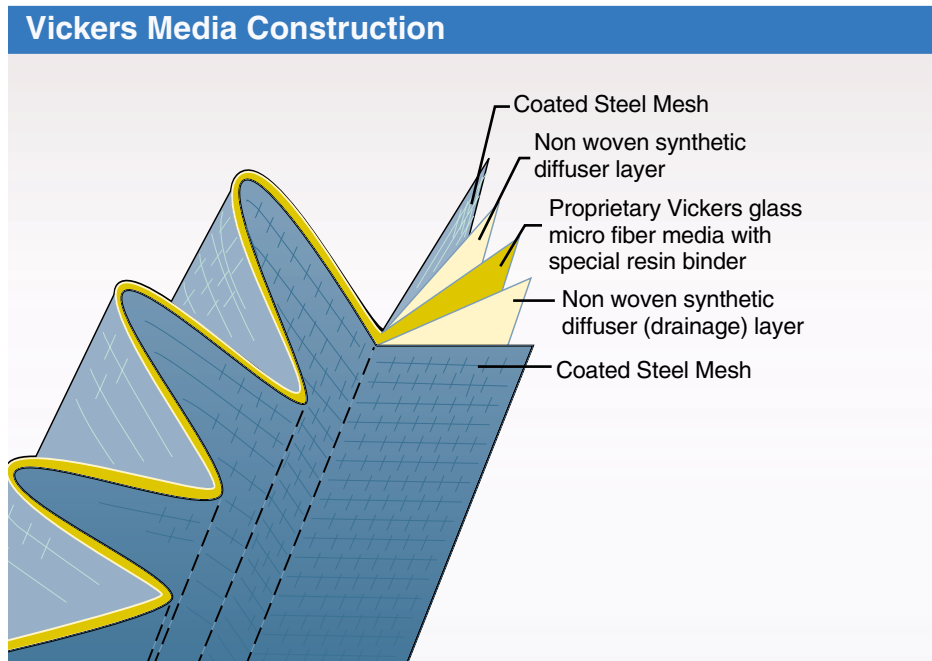

Limits on Correlation Between “Beta” and System Cleanliness and “Dirt Capacity” and Service Life		
	Laboratory Procedure	Real World
Pressure Rise	One gradual rise	Thousands of changes
Fatigue Cycles	One	Millions
Element Aging	Minutes	Months
Element Life	One hour	800+ hours
Contaminant	AC fine test dust	Debris, water, gas
Challenge Rate	Constant	Always changing
Fluid Used	MIL 5606	Wide variety
Temperature	100°F (38°C)	-20°F to 200°F (-7° to 93°C)
Flow	Steady	Thousands of changes

System Cleanliness Ratings

Code	Number of times flow from pump passes through the system filters (See Note 1)	Typical ISO 4406 cleanliness level achieved (See Note 2)										
03	2.0	14/12/10										
	1.5	15/13/11										
	1.0	16/14/12										
	.5	17/15/13										
05	2.0	16/14/12										
	1.5	17/15/13										
	1.0	18/16/14										
	.5	19/17/15										
10	2.0	18/16/14										
	1.5	19/17/14										
	1.0	20/18/15										
	.5	21/19/16										
Note 1 <table border="1"> <thead> <tr> <th>Systems Flow Passes thru Filters</th> <th>Typical Filter Placements</th> </tr> </thead> <tbody> <tr> <td>2.0</td> <td>Full flow pressure and return</td> </tr> <tr> <td>1.5</td> <td>Full flow pressure or return and recirculation loop</td> </tr> <tr> <td>1.0</td> <td>Full flow pressure or return line</td> </tr> <tr> <td>0.5</td> <td>Recirculation loop sized to 15% of system volume per minute</td> </tr> </tbody> </table>		Systems Flow Passes thru Filters	Typical Filter Placements	2.0	Full flow pressure and return	1.5	Full flow pressure or return and recirculation loop	1.0	Full flow pressure or return line	0.5	Recirculation loop sized to 15% of system volume per minute	Note 2 Cleanliness level achieved is affected by percentage of system flow that passed thru the filters, filter housing integrity, element performance and contamination ingress and generation rates. For more detailed assistance, please contact your local Vickers Distributor.
Systems Flow Passes thru Filters	Typical Filter Placements											
2.0	Full flow pressure and return											
1.5	Full flow pressure or return and recirculation loop											
1.0	Full flow pressure or return line											
0.5	Recirculation loop sized to 15% of system volume per minute											

For target cleanliness level selection assistance and proper filter placement guidelines, consult your local Vickers Distributor.

Filter Efficiency Under Stress

A major problem in correlating multipass test claims to real world fluid cleanliness levels is that real systems operation greatly stresses the element. In active systems, flow rate changes (often several a minute), pressure pulses (hundreds a minute), decompression shock waves, cold starts, and other variables all work to degrade a filter's performance. In multipass testing the element is subject to one gradual rise in differential pressure as the element loads!

Flow fatigue test protocol (ISO 3724) leaves many important questions unanswered. Again the element is tested in laboratory conditions that cannot duplicate the interaction of the many forces working to stress and degrade the element. This laboratory test may fail to answer the question of how an aged element will perform during the latter part of its service life.

The best way to deal with this issue is to look at the construction and feel the element pleats. Are the pleats well supported? Do they flex under hand pressure? Any element that fails these simple tests will fail to maintain efficiency and integrity, and will not maintain the targeted cleanliness level.

Additionally, look at the pack construction. Steel wire mesh is very important in element construction. Wire keeps the pleats from flexing, and gives the filter medium the support it needs to keep from failing due to fatigue. The downstream wire mesh also serves as a last chance protection in case of unexpectedly severe stress that causes element media rupture.

Changes in Flow

In poorly supported elements, changes in flow and pressure drop cause the sides of element corrugations to flex and the root to stretch, giving rise to fatigue stresses. Dirt capacity is also lost as areas of the medium have no flow.

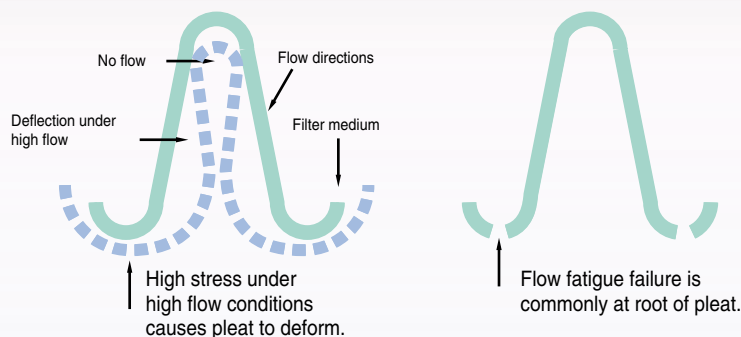

Elements without downstream wire mesh are not recommended for use in hydraulic or lubrication systems with even mild stress. This rule is important as the relatively higher cost of wire mesh has lured some filter manufacturers to take the wire mesh out and use cheaper substitutes without dealing with the real world issues of stress and last chance protection.

Filter Matrix Breaking

Without proper support, the fibers forming the bonded media layer can deform, allowing contamination to pass through the filter.

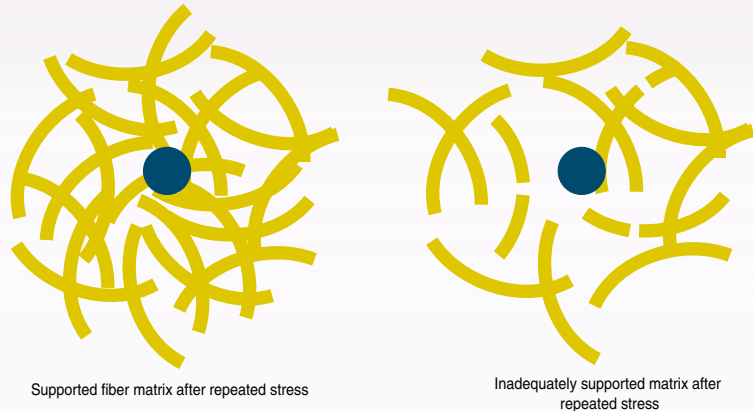

Filter Placements

This chart helps the engineers select the grade of media and the filter placement(s) that will achieve the required target cleanliness. It assumes the system will experience “average” ingressions and that maintenance of the system will be consistent with current technology. If in operation the system is running dirtier than expected, corrective actions should be initiated. Suggested corrective actions are:

1. Consider using a finer grade of media.
2. Add a filter to the system.

Target Cleanliness	Full flow pressure line or return line	Full flow pressure line and return line	Pressure or return and recirculating loop at 20% of system volume per minute	Pressure line plus return line plus recirculating loop	Recirculating loop at 20% of system volume per minute	Recirculating loop at 10% of system volume per minute
14/12/10		03	03	03		
15/13/11		03	03	05		
16/14/12	03	05	05	05	03	
17/15/13	03	05	05	05 or 10	03	03
18/16/14	05	10	05 or 10	10	05	03
19/17/15	05 or 10	10	10	10	05 or 10	05

	Recommended filter placements for high ingressions systems with fixed volume pumps	Recommended filter placements for systems with variable volume pumps	Recommended filter placements for high ingressions systems with variable volume pumps			
--	--	--	---	--	--	--

Note: All systems need a sealed reservoir with 3 micron air filtration.

Locating Contamination Control Devices in Open Loop Applications

Main System Contamination Control

- Pressure Line
- Return Line
- Recirculating Loop
- Component Isolation
- Sensitive Components
- Safety Issues

Pressure Line Filters

- Fixed Volume over 2250 psi (155 bar)
- Variable Volumes over 1500 psi (103 bar)
- System with Servo or Proportional valves

Locating Contamination Control Devices

Hydraulic Systems — Open Loop

Filter placements in hydraulic systems can be categorized by the three major functions they can perform. These are: ingress prevention, system cleanliness maintenance, and component isolation.

Ingression prevention

All air entering the reservoir needs to be filtered. Removing dirt from air is many times easier than removing it from oil. The first step is to make sure the reservoir is sealed and to ensure that the exchange air enters the reservoir only across sufficiently-sized air filters

that are able to extract particles of a size of 3 μm or more from the air. The port(s) needs to be fitted with a Vent Filter designed to remove particles 3 μm and larger from the air (grade “10”).

All fluids entering the system should pass through a high efficiency filter (grade “03”) before they are added to a system. This is often accomplished by fitting a Transfer Cart with a filter directly downstream of the pump and then using a quick connect coupling (half mounted to the reservoir, half on the discharge hose) requiring the fluid to be pressure pumped into the reservoir. An alternate plan is to have a procedure that requires the fill fluid to pass through the return line filter to enter the system. A third alternative is to use the recirculating pump as a fill pump with the filter in the kidney loop to clean the new oil.

Pressure Line Filter

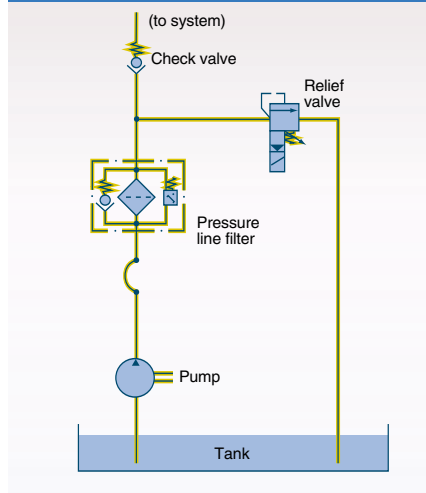

Pressure and Return Line Filtration

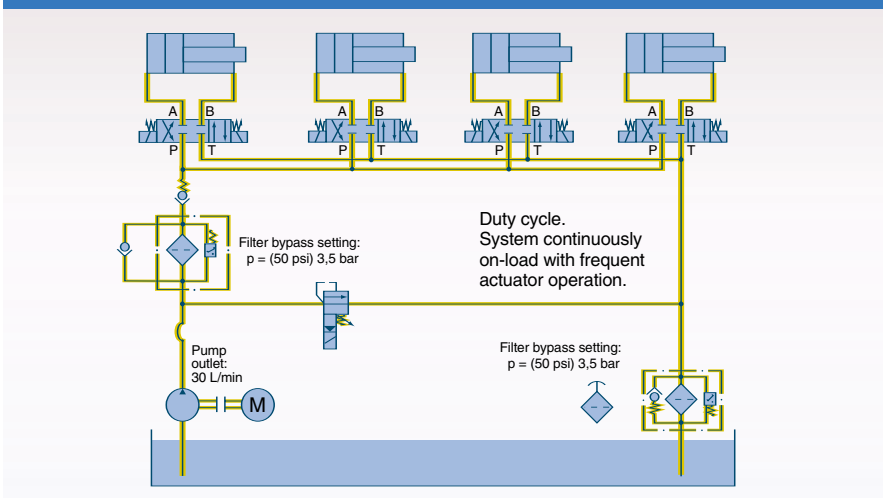

Maintaining System Cleanliness

There are three main places in a circuit where contamination control filters should be located: Pressure line(s), Return line(s), or Recirculating loop.

A pressure line filter should be fitted directly downstream of any fixed volume pump operating over 2250 psi (155 bar) and any variable volume pump operating over 1500 psi (103 bar). The rotating group of a pump has a mixture of sliding and rolling contact surfaces which are stressed by high pressure or changing pressure operation. As such, an operating pump is always producing some wear debris. For systems with servo or proportional valves, a high pressure filter should always be used regardless of pump type or pressure. The pressure line filter should be considered the total system contamination control device only if it sees maximum pump flow during more than 60% of the machine duty cycle. If no additional return filter is used, this layout allows the dirt returned from the system to

pass the pump, therefore causing increased wear in the pump before it is filtered out.

The return line is an excellent location for the main system contamination control filter, as long as it sees at least 20% of system volume each minute. In cases where return line flow is less than the 20% minimum (periods of operation with the pump in compensation), a supple-

mentary recirculating pump and filter should be designed into the system. Often systems that need recirculating filters also need off-line cooling loops; both these needs can be met by a single pump/motor with the filter upstream of the cooler.

Flow amplification can cause problems for return line filters. Cylinders with a 2:1 or greater differential area between

the piston area and rod side piston area mean that during part of the machine duty cycle flow rates can be 2 times pump flow or more. In systems with very high or severely pulsating flows, recirculating loop filters are often the best choice.

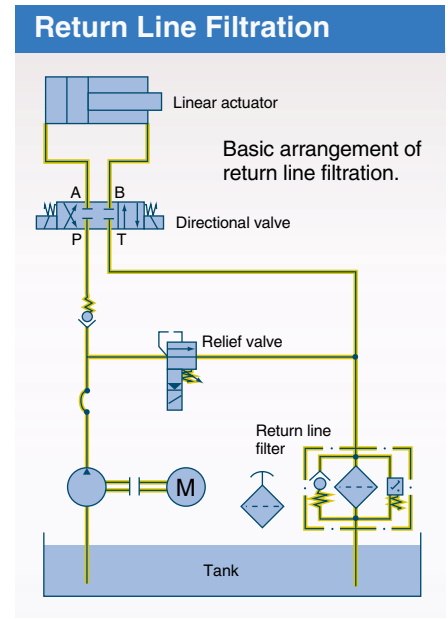
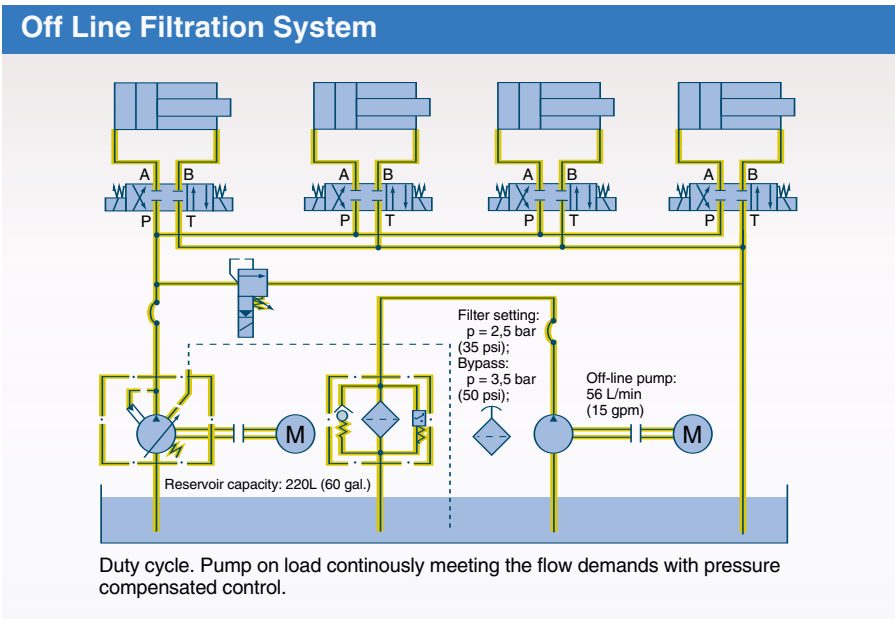

Component Isolation

Protects:

- High Cost Components
- Safety Functions
- Against High Cost Downtime

Protects Sensitive Components:

- Servo Valves (all brands)
- Proportional Valves (all brands)

Component Isolation

Filters to isolate components should be considered for systems or machines to protect downstream components in the event of a pump or other major component failure. Additionally, certain classes of components need dedicated protection based on their design clearance or fine metering edges.

Whenever a primary failure can cause a secondary failure with unacceptable consequences, an isolation filter or strainer should be placed upstream of that component. Since pumps have finite life and as they fail the debris travels downstream to the valves, care should be taken to place a strainer in-line ahead of any valve that has a safety consideration or critical function to the system.

Servo and proportional valves have fine tolerance spools that modulate in reaction to small changes in pilot flow or proportional solenoid forces. Even small quantities of fine silt can cause degraded operation. Individual valves or banks of valves should be isolated with a non-bypass filter that protects these components from silt and chips that could enter a system during maintenance of other components. For large servo or proportional valves with external pilot flow, a smaller, less expensive non-bypass filter **1** can be placed in the pilot line while the main valve is protected by the system filter **2**. Filter **3** is an optional location. A common mistake that should be avoided is selecting a component

isolation filter that is finer than the system filter. This forces the isolation filter to perform the general system clean-up function, and results in very short element life.

A location not recommended for filter placement is in the case drain flow from open or closed loop pumps. The shaft seal on all pumps must maintain a zero leak seal under very low differential pressure conditions. These seals experience accelerated wear whenever additional back pressure is added to the pump case. If a filter is being considered in a case drain application it should be reviewed with consideration of the effect it will have to the shaft seal life.

Pressure Line Filtration

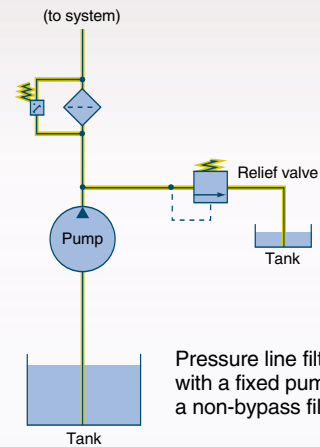

Hydraulic Systems—Closed Loop

The fluid cleanliness level that is significant to a closed loop hydraulic system's long-term dependability is the "in-loop" fluid cleanliness. Normally a high efficiency filter in the charge pump line will maintain the required cleanliness. But, for hydrostatic transmissions running at or near their maximum pressure, in-loop filters with reverse flow valving are recommended. These filters will also protect the motor in case of a pump failure. Remember to consider the percentage of time the transmission runs in each direction when locating the filter. For bi-directional operation with approximately 50% of the duty cycle in each direction, two filter housings should be used.

Closed Loop Hydrostatic Transmission

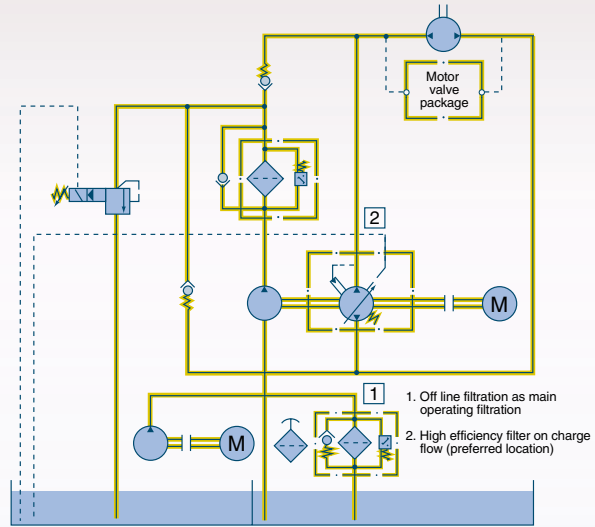

Non Bypass Filter Ahead of a Servo Valve

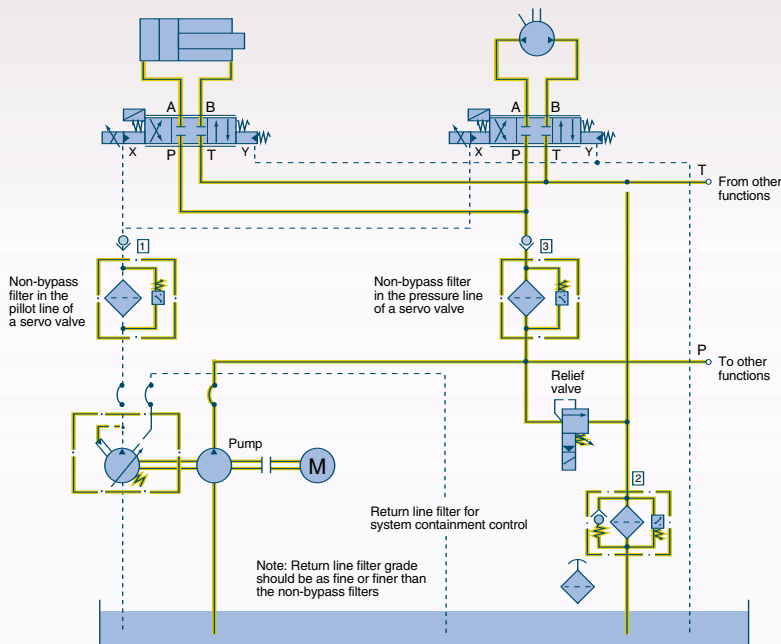

Central Lubrication System

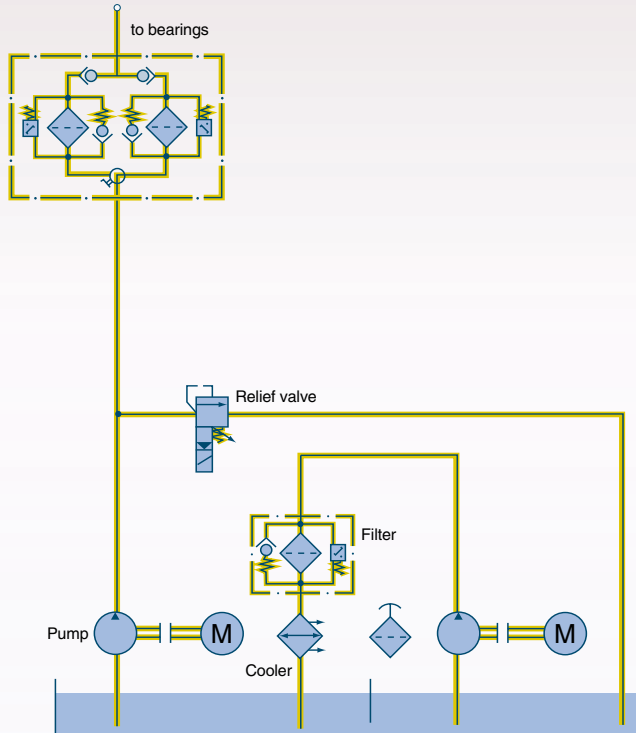

Central lubrication system with Duplex filters and a recirculation cooling and filtration loop.

Lubrication Systems

There are two locations for filters in a lubrication system: pressure line and recirculating loop. For pressure line operation, the filter should be “duplexed” allowing for on line element change while the system is in operation. Recirculating loop filters are excellent (application location) as long as the loop flow is at least 50% of the main pump flow.

Filter Condition Indicators

After the filters are placed within the system, the next consideration is how the user is going to know when to change the element. The answer recommended in DIN 24550 standard is to have all filters fitted with a differential pressure indicator that gives an easy-to-read indication that the element needs to be changed. Vickers indicators are designed to indicate at a pressure drop 20% below the bypass setting which equates to 95% of the element's service life. This indication before bypass feature was incorporated to allow safe operation of the machine until the next shift change or convenient maintenance opportunity.

Filter Condition Indicator

- All filters should be fitted with a condition indicator

Element Differential Pressure Build-up with Dirt Loading

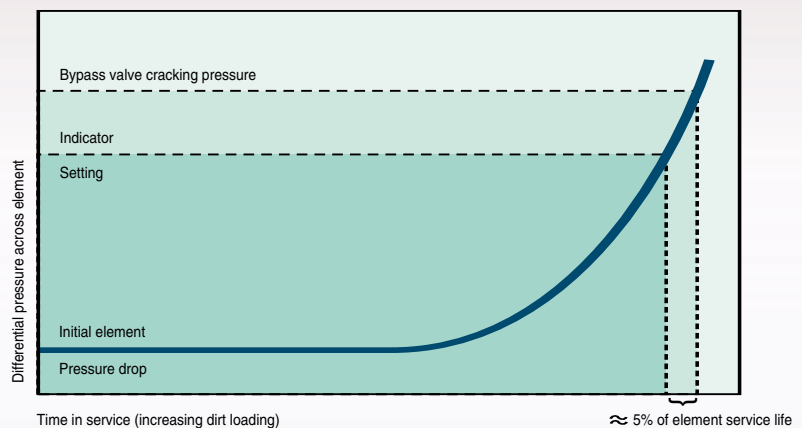

Flushing New or Rebuilt Systems

The most critical time in the life of a hydraulic or lubrication system is the initial run-in period. During this time much of the manufacturing debris in the components and any debris added during the assembly process are washed through the system. It is critical that this contamination be captured quickly and removed from the system while it is in off-load operation.

New System Flushing

There are three steps to a flushing process. First, the machine must feed system fluid through all lines and components. Second, this process must dislodge the dirt from all components and lines, and third, the contaminations must be captured with a high-efficiency filter. Dislodging and transporting dirt is best accomplished by using a low viscosity fluid traveling at high line velocity. Special flushing fluid can be used or the actual system hydraulic fluid can be used at an elevated temperature. To get flow through all the lines, all the valves should be operated several times. In some cases, lines need to be connected around a component to allow high flow fluid to travel through the line. Capture of the debris to flush to a cleanliness level of **16/14/11** reasonably quickly is best accomplished with a Vickers filter using "05" media. This product has the combination of high efficiency and high capacity needed to achieve a successful flush.

Flushing target cleanliness levels should be two ISO codes below the target cleanliness level for system operation. When the new oil is introduced into the properly flushed system, less time and filter element life will be consumed reaching system equilibrium.

Element Service Life

As in any aspect of machine design or maintenance, cost of installation and operation is a very important concern. For filters, the length of time an element lasts in service, and the initial cost of that element, combine to determine the economics of using that product.

The most important aspect of gaining long element service life is to minimize the ingress! Reservoirs need to be fitted with vent filters ($\leq 3\mu\text{m}$) that remove the dirt before it enters the system.

Access port and doors need to be kept sealed so that dirt cannot be drawn into the system. Cylinder rods that extend into contamination laden environments should be shielded to minimize the dirt being drawn into the system.

The second important aspect to long element service life is to keep the cleanliness level of the fluid at or below target. Periods of machine operation with dirty fluid cause accelerated internal wear that loads a filter element. (It's important the debris is caught as it saves the system, but it does cost the element part of its service life.) Always change an element on indication and always use genuine Vickers elements because of their consistent performance and superior strength under stress.

New System Flushing

- Dislodge the dirt and transport it to the filter
- Flow fluid through all lines and components
- Capture the dirt with a high efficiency filter

Element Service Life

- Minimize ingress
- Maintain a constant cleanliness
- Use an element with high dirt capacity
- Use elements with greater media area

The third issue in long element service life is the “dirt capacity” of the element. This value is calculated as part of the multipass efficiency test. Because of the many differences between the test conditions (Fine Test Dust [ACFTD] contamination, single pressure rise, etc.) and real system operation, different dirt capacity values do not correlate well to changes in element service life. Dirt capacity can only be used to compare elements under very specific laboratory situations, and as a result published dirt capacity values should be used as general information rather than specific comparable data.

Vickers elements are designed to give long life and reliable service in hydraulic or lubrication applications. This is achieved with our multi-layer construction. Each layer provides additional strength or capacity leading to overall superior performance. Some elements focus heavily on media structure only, which can give increased “dirt capacity” under laboratory conditions, but no increase in service life is experienced in real systems.

An often overlooked aspect of dirt capacity and service life is the effect of element area. When comparing an element of “x” area with an element of “2x” area, one would expect twice the life for the larger element. But, in real systems, the life extension is most often between 2.5 and 3.5 times as long. This is because the reduced flow density through a unit area of media allows for more effective contaminant capture. Larger elements are the most cost effective approach to contamination control from the perspective of operating costs.

Element Service Life versus Element Area

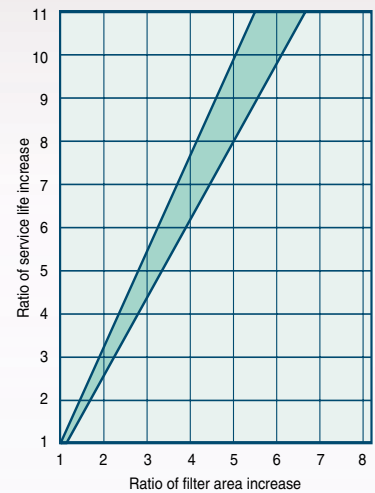

Confirming and Monitoring Achievement of Target Cleanliness

Once the target cleanliness level has been set, and the filters have been selected and located in the system, the last and ongoing step is to confirm and monitor that the target cleanliness is being achieved. The best way to confirm the target is being reached is to take a representative sample from the return line, ahead of the filter and send it to a qualified laboratory that reports particle counting per ISO 4406 (modified to include 2µm counts).

Quality laboratories, like the Vickers Fluid Analysis Service, report the cleanliness level with three ranges codes corresponding to 2µm, 5µm, 15µm. From this information, it is possible to determine that the hydraulic or lubrication system has the clean fluid it needs for long dependable operation.

New developments in the environmental sciences have resulted in passage of laws concerning the disposal of used hydraulic or lubrication fluids. Cost conscious users of petroleum products have discovered that it is far more cost effective to extend useful oil life by as much as 4-6 times through better contamination control and Systemic

Contamination Control practices, thereby avoiding the high costs of frequent replacement and disposal of aged fluids. For more detailed information on how you can realize these savings contact a Vickers distributor trained in systemic contamination control.

Taking A Representative Sample

Taking a representative sample is a very exact science. Generally, the right place to sample a system is in the return line directly ahead of the return line filter. It is good system design to install a permanent sampling valve in that location. Alternate locations for sampling are to take a reservoir sample using a vacuum pump and clean tubing, or sampling from the pressure line directly downstream of the pump. An important factor with reservoir sampling is to be sure the end of the sampling tube is about half way down into the fluid, otherwise "stratification" within the reservoir can cause the sample to be non-representative. Reservoir sampling is the least recommended alternative because of the potentially inconsistent sampling and the need to open the system, inviting contamination, to obtain the sample.

Monitoring System Cleanliness

- Sample from the return line ahead of the return line filter
- Sample from an active system
- Obtain particle counts for 2 µm, 5 µm and 15 µm

Fluid Sampling Kit

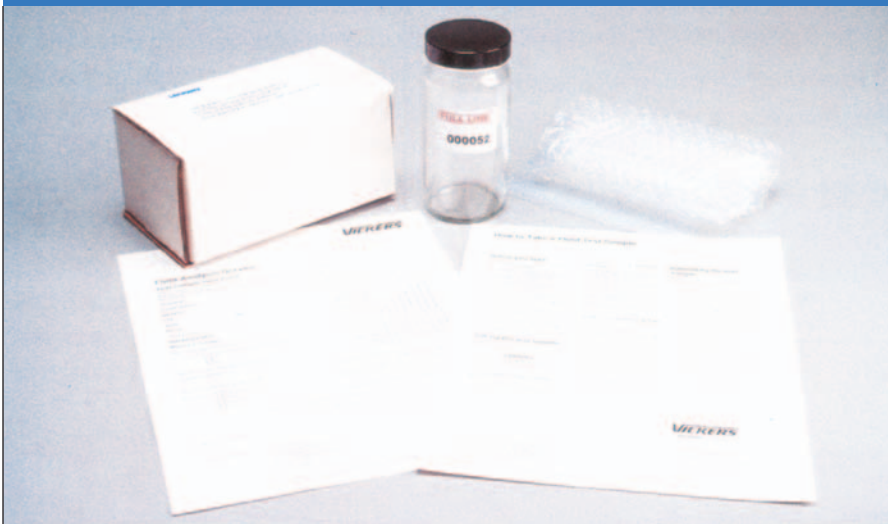

Vickers Fluid Analysis service provides: Ultra clean sample bottle • Sampling instructions • Submittal form • Protective bag • Mailing box

New Oil versus Filters

- The high financial and environmental cost of oil disposal makes filtering the better option

In all sampling situations it is critical that the system be in operation or just shut down when the sample is taken. This assures that the fluid is turbulent and that the contamination in the system is circulating and available to be captured in the sample bottle.

Once the cleanliness level has been achieved and confirmed, normal maintenance practices dictate that a system be resampled at regular intervals to reconfirm that the proper cleanliness level is being maintained.

If the cleanliness level code value rises, meaning the system is running dirtier than it should, the first thing to check is if new ingress is entering the system. Check to be sure that all access doors are closed and that the vent filters are fitted and operational. Next, check to see if the filters are on bypass; if so, replace them with the appropriate genuine Vickers filter elements. Lastly, it may be necessary to add a filter to the system. The most common solution is to add a recirculating loop, (pump, motor and filter) to the reservoir.

After any maintenance activities which may introduce contamination, such as hose replacement or pump repair, a new sample should be taken to confirm that the target cleanliness level is still being maintained.

Recommended System Sampling Frequency Chart

Systems with target cleanliness 17/15/12 or lower			
System Pressure	< 2000 psi (140 bar)	2000 - 3000 psi (140 - 210 bar)	> 3000 psi (210 bar)
8 hours of operation per day	4 months	3 months	3 months
Over 8 hours of operation per day	3 months	2 months	2 months
Systems with target cleanliness 18/16/13 or higher			
System Pressure	< 2000 psi (140 bar)	2000 - 3000 psi (140 - 210 bar)	> 3000 psi (210 bar)
8 hours of operation per day	6 months	4 months	4 months
Over 8 hours of operation per day	4 months	3 months	2 months
<p>Note: Initial commissioning or major rebuild</p> <p>Large system (2000 liters (530 USgal) or more) and systems with servo valves</p> <ul style="list-style-type: none"> • Sample fluid before start-up • Sample fluid during first day running • Sample fluid after one week • Sample after one month operation <p>Other systems</p> <ul style="list-style-type: none"> • Sample during first day running • Sample after one month operation <p>Systems in distress or immediately after a maintenance event</p> <p>(i.e. increased heat, erratic operation, unusual sound, etc.)</p> <ul style="list-style-type: none"> • Immediate 			

ProActive Maintenance

An important new technology currently being developed for hydraulics and lubrication systems is ProActive Maintenance. The concept, a significant part of systemic contamination control, is to place sensors in the fluid flow and allow their outputs to be combined and computer analyzed to make diagnostic statements about the operational health of the machine. This emerging technology holds great promise for increasing the reliability of fluid power and oil lubricated machines. Vickers is the leader in the development of both Systemic Contamination Control and ProActive Maintenance technology.

Eaton Support

Eaton is committed to assisting users of hydraulic and lubrication systems to achieve the long reliable service life designed into these systems. Our factory and distributor personnel are well trained in systemic contamination control and can help both design and maintenance engineers. If you have any questions, or need additional assistance, please feel free to call Eaton or our local distributor.

EATON WARRANTY EXTENSION

Eaton is committed to the practice of systemic contamination control and superior performance of our filter products.

Eaton will extend **by three years**, the standard warranty on **all Eaton products** used in a system that is protected by Eaton filters (and elements) applied consistently with the principles presented in this document.

VICKERS SYSTEM SOLUTIONS

Vickers is a leading manufacturer and distributor of engineered power and motion control products and systems for industrial, off-highway, agriculture, aerospace, marine and defense applications worldwide. No matter what industry you work in, chances are Vickers does, too.

We meet industries' demanding fluid power needs with a complete line of products including hydraulic pumps, motors, valves and cylinders; electronic and hydraulic controls; electric motors and drives; filters; and fluid-evaluation products and services.

Vickers innovation is at work all over the world with manufacturing and assembly facilities located across five continents, and more than

300 sales and service centers in 60 countries. Our products and systems are designed and manufactured to meet or exceed all global standards. And with the

support of our global network of distributors, we provide complete system design assistance, aftermarket service and genuine Vickers parts on a worldwide basis.

PRODUCTS	MARKETS														
	Automotive (Car, Truck and Bus)	Plant Maintenance (All Industries)	Construction	Mining Aggregates	Farm	Marine (Ships, Boats and Docks)	Materials Handling	Railroads	Logging	Industrial Plant Equipment	Processing Industries	Petroleum Products and LIFT Trucks	Machine Tools	Special Industrial, Medical, Textile	Entertainment
Motor Pumps															
Servo and Proportional Valves and Systems															
Cartridge Valves, Manifold Systems															
Directional, Flow, Relief and Pressure Control Valves															
Hydraulic Remote Controls															
Filters, Reservoirs and Accessories															
Hydraulic Power Packages															
Marine Central Control Hydraulic Systems															
Piston and Vane Motors - Fixed and Variable															
Piston and Vane Pumps - Fixed and Variable															
High-Pressure Hydraulic Systems															
Hydrostatic Transmissions															
High Water-Based Fluid Systems and Components															
Hydraulic and Pneumatic Electronic Controls															
Servo Motors and Drives															
DC Drives															
DC Motors															
Motion Control Products															
Debris Monitoring and Collection Systems															
Level Sensing Devices															
Electrohydraulic, Hydraulic and Pneumatic Cylinders															

Eaton
14615 Lone Oak Road
Eden Prairie, MN 55344
USA
Tel: 952 937-9800
Fax: 952 974-7722
www.hydraulics.eaton.com

Eaton
20 Rosamond Road
Footscray
Victoria 3011
Australia
Tel: (61) 3 9319 8222
Fax: (61) 3 9318 5714

Eaton
46 New Lane, Havant
Hampshire PO9 2NB
England
Tel: (44) 23 92 486 451
Fax: (44) 23 92 487 110

